

# APPLICATIONS

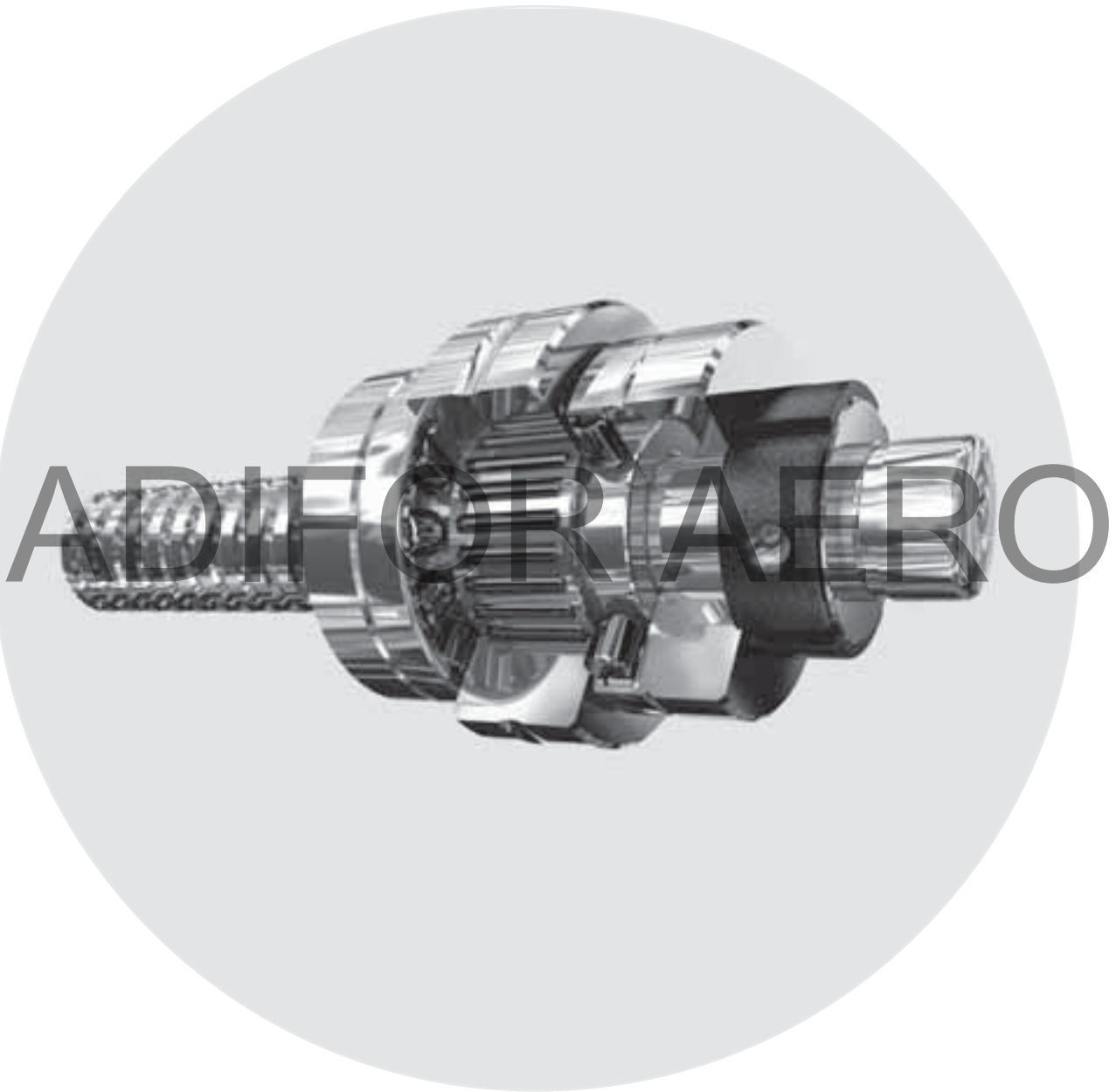

# Applications

## TWO STROKE ENGINE FOR PORTABLE SAW

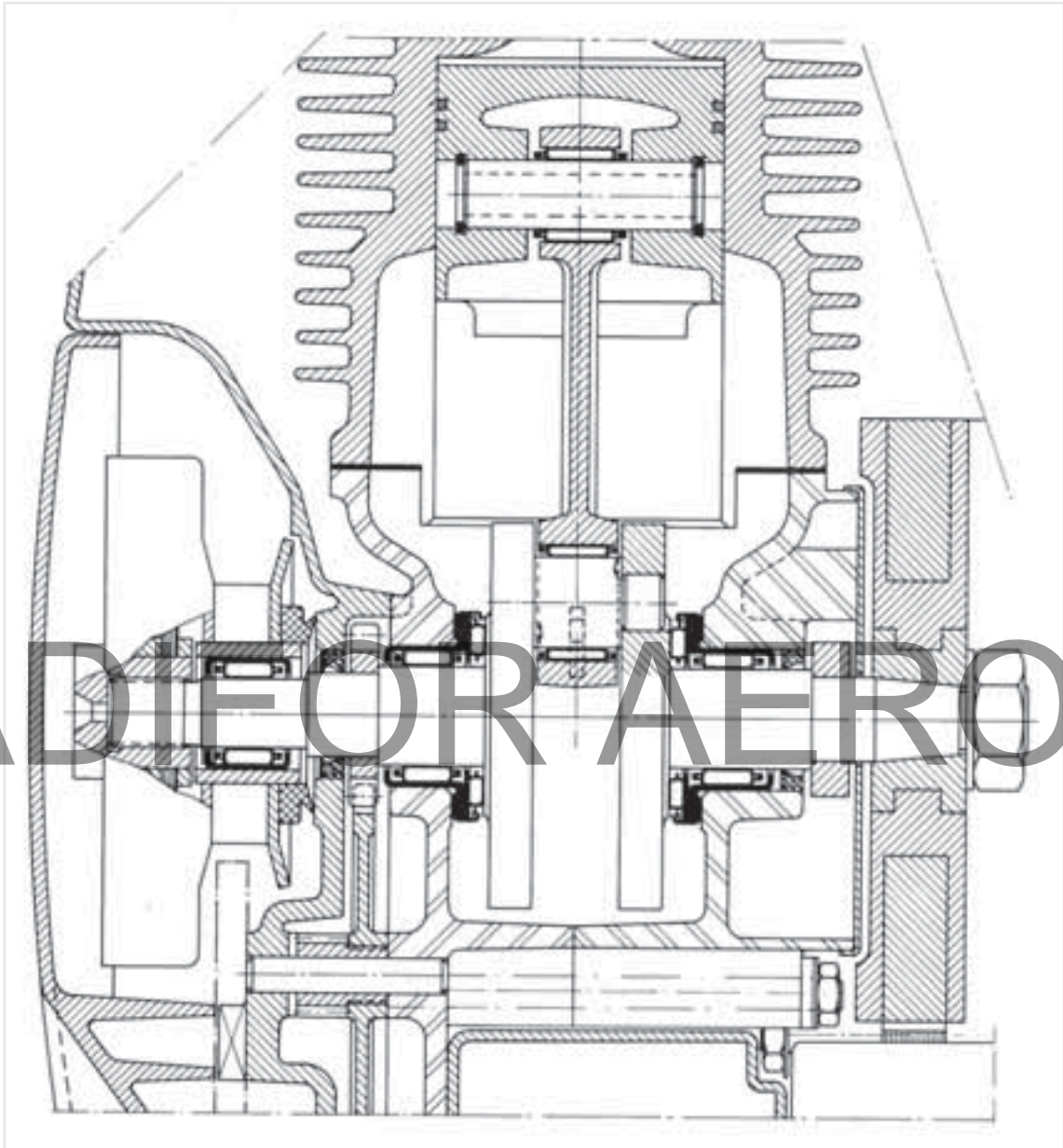

The high speeds attained by these engines subject the connecting rod bearings to extremely arduous working conditions, made worse by doubtful lubrication and high operating temperatures. Needle cages provide the solution to these difficulties, by virtue of their small size and special manufacturing methods. In the big end of the connecting rod, the steel cage is specially treated and is centred on its outside diameter.

In the little end, on the other hand, the needle cage is centred internally on the gudgeon pin. The cage extends beyond the width of the rod, thereby allowing the maximum possible length of needle to be utilised with consequent reduction of unit load.

Lateral location of the rod is ensured by the crankshaft webs, giving adequate clearance between the little end and the internal bosses of the piston.

The crankshaft runs in two RAX 714 combined bearings to carry the radial loads and provide axial location the least possible space. They are sealed by two DH lip seals. In the disengaged position, the pulley is supported by a HK 10 12 caged Needle Bushes. All faces and shafts acting as needle raceways are case hardened to 58 – 60 HRC.

# Applications

## OFFSET PRESS- PAPER FEEDING MECHANISM

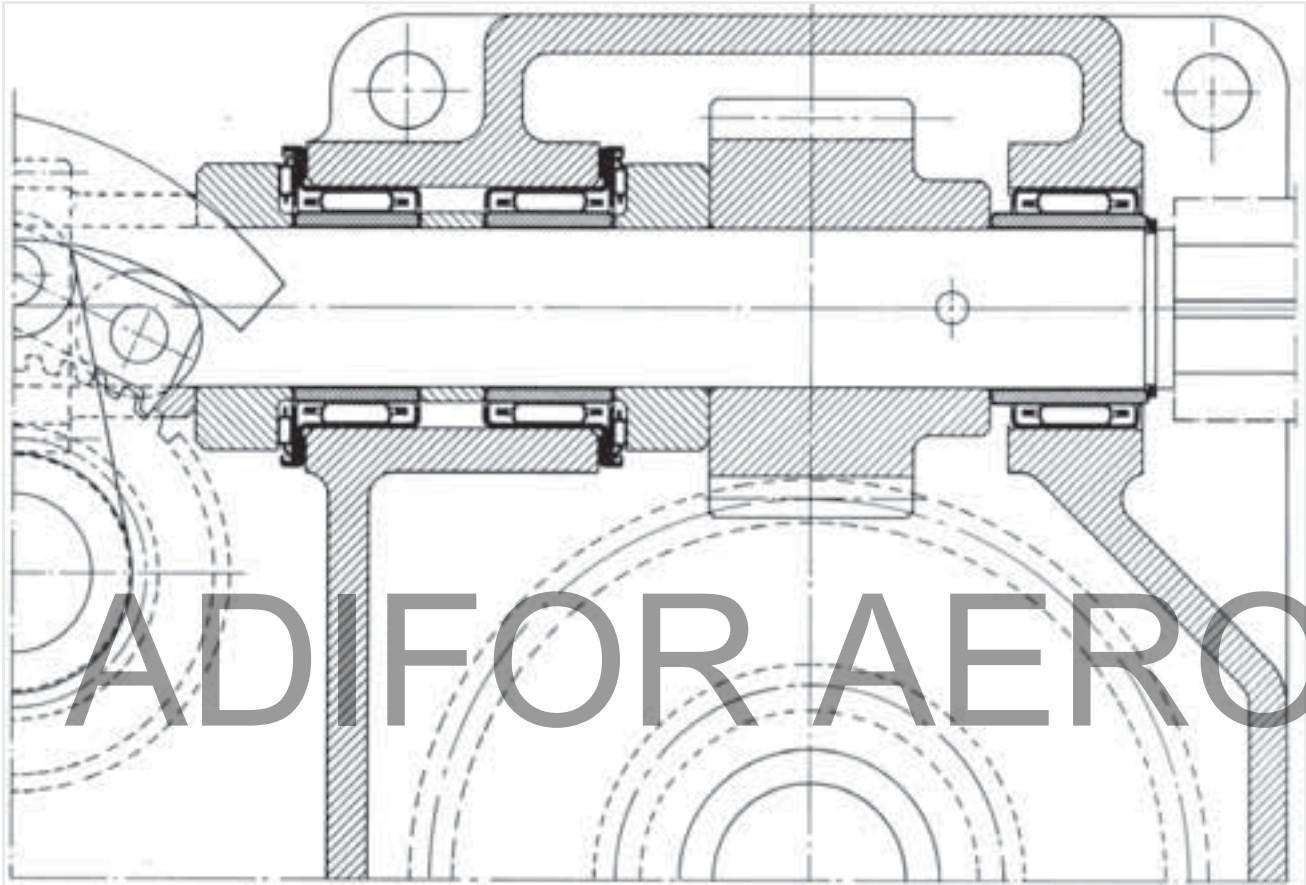

The pinion shaft is supported at one end, by two RAX 730 thin wall combined bearings, which ensure lateral location in both directions. The other end of the shaft runs in a HK 30 20 caged needle bushes.

The use of inner race avoids the necessity for hardening the shaft journals.

# Applications

## FOLLOWERS FOR OVERHEAD CONVEYOR

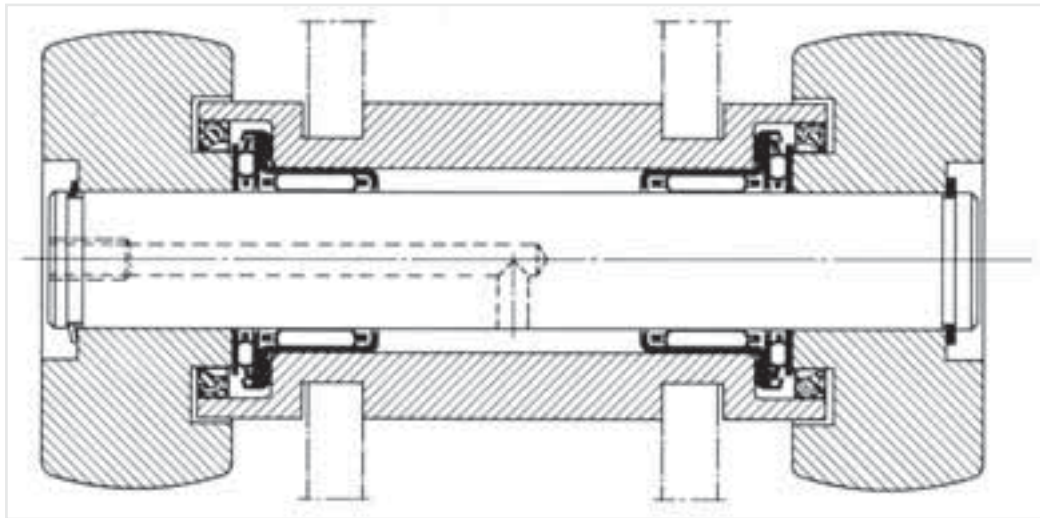

# ADIFOR AERO

The common spindle carrying the two rollers turns between two RAX 718 combined bearings (with thrust plates) which ensures lateral location in both directions. The bearing surfaces of the shaft are hardened to 58 HRC.

Lubrication is by grease introduced via a nipple on the end of the shaft.

Sealing is effected by sealing rings type DH28x35x4.

# Applications

## LEAD SCREW BEARING FOR AUTOMATIC LATHE

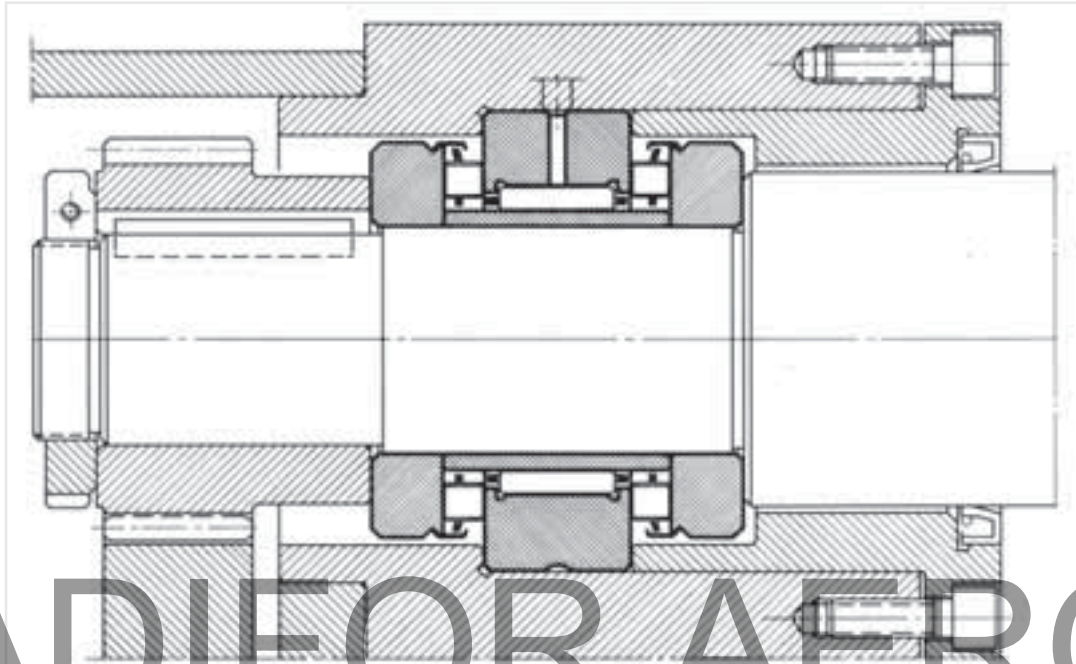

# ADIFOR AERO

For this application, Nadella has introduced a special precision combined bearing type ARNB ensuring the axial rigidity of the screw, permanently without play, by virtue of the behaviour of thrust races under controlled

preload. This preload, by the lock ring at the end of the pinion, is adjusted precisely to the desired value, whilst assembled, by measuring the torque required to turn the screw, this being a function of the axial loading.

# Applications

## MILLER/BORER - GEAR BOX

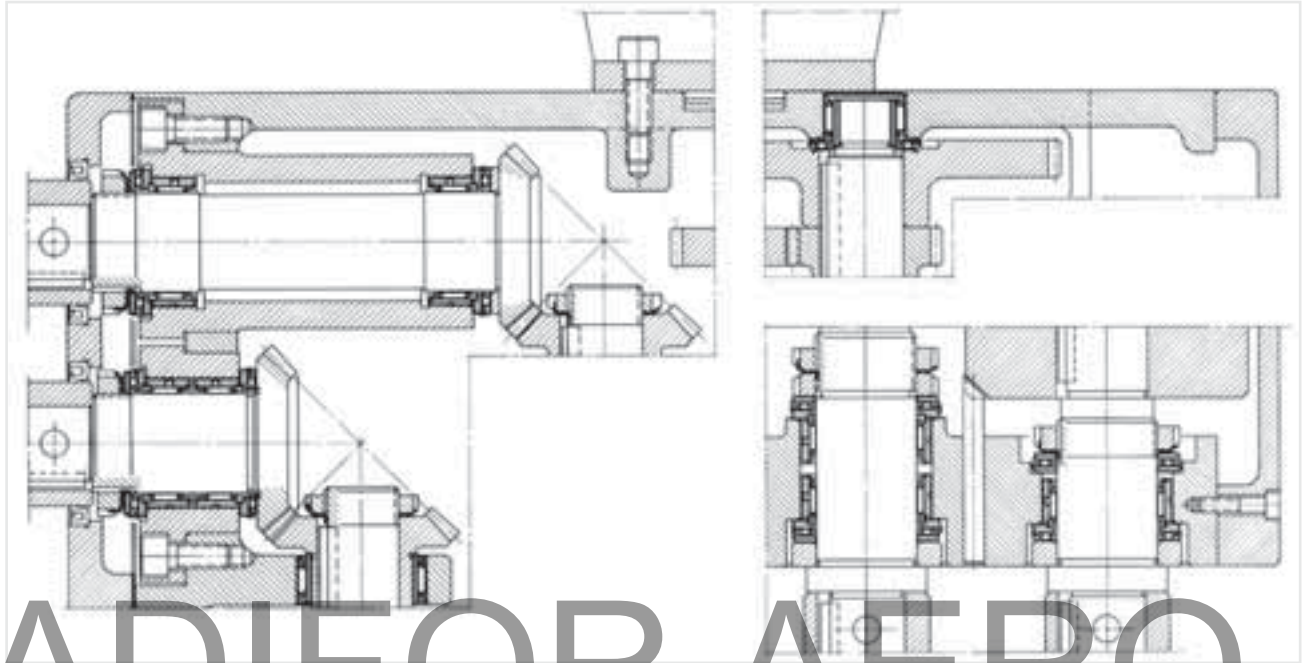

# ADIFOR AERO

This assembly is particularly interesting in the method of radial and axial location of gears and spindles, by means of two RAX 400 combined bearings mounted in opposition which, even though located in close

proximity, ensure adequate support. Of equal interest is the RAX 700 thin wall combined bearing whose closed end ensures perfect shaft sealing.

# Applications

## BORER SPINDLE

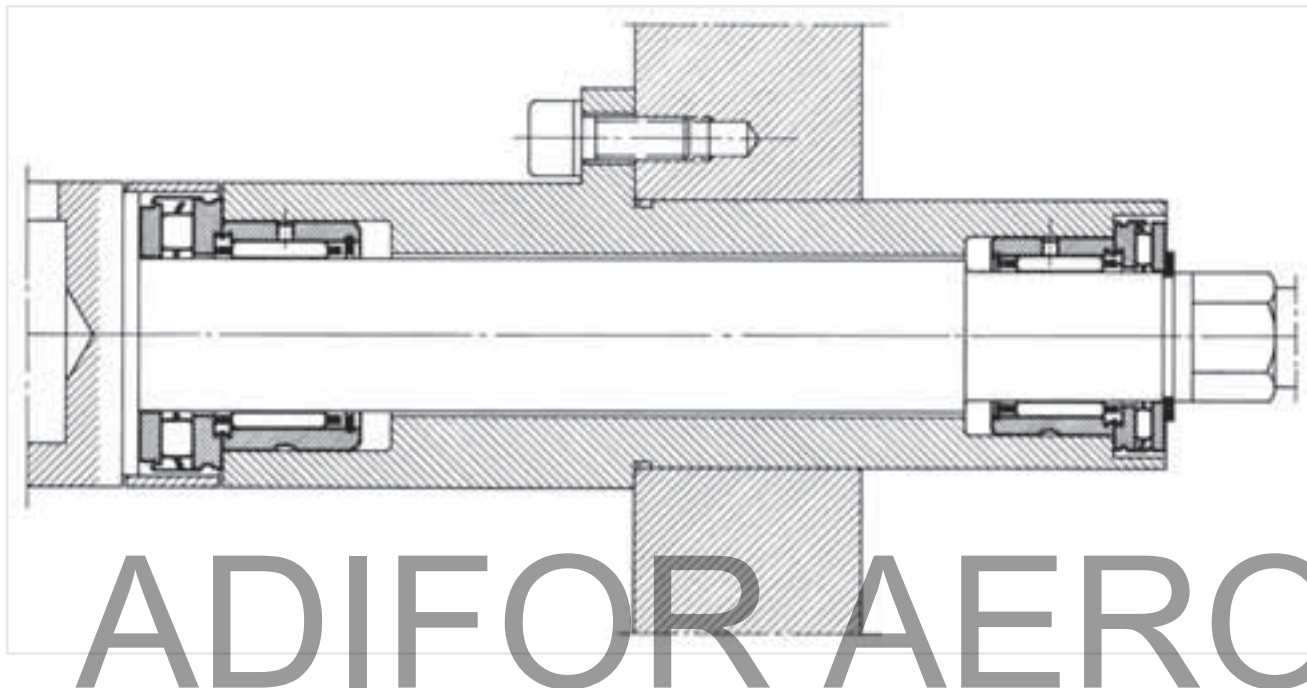

Case hardening the ends of the shaft to 60 HRC allows the use of bearings without inner rings. The front journal is fitted with an RAXZ 520 combined bearing with roller thrust and integral thrust washer. The inside diameter of the radial part of the bearing is held to tolerance F6, and the shaft to k5, giving the necessary low play for this precision application.

The thrust rollers of the combined bearing withstand the main axial loading. It is shielded from ingress of foreign

bodies by the cover which retains the thrust washer and by a sleeve over the assembly. The rear housing incorporates an RAX 417 combined bearing (with thrust washer CP 2 17 30) on a k5 shaft. The needle thrust taking the axial loadings in the opposite direction to the main working load. A speed of 1 500 r.p.m. allows the use of grease for lubrication.

# Applications

## HAND DRILL

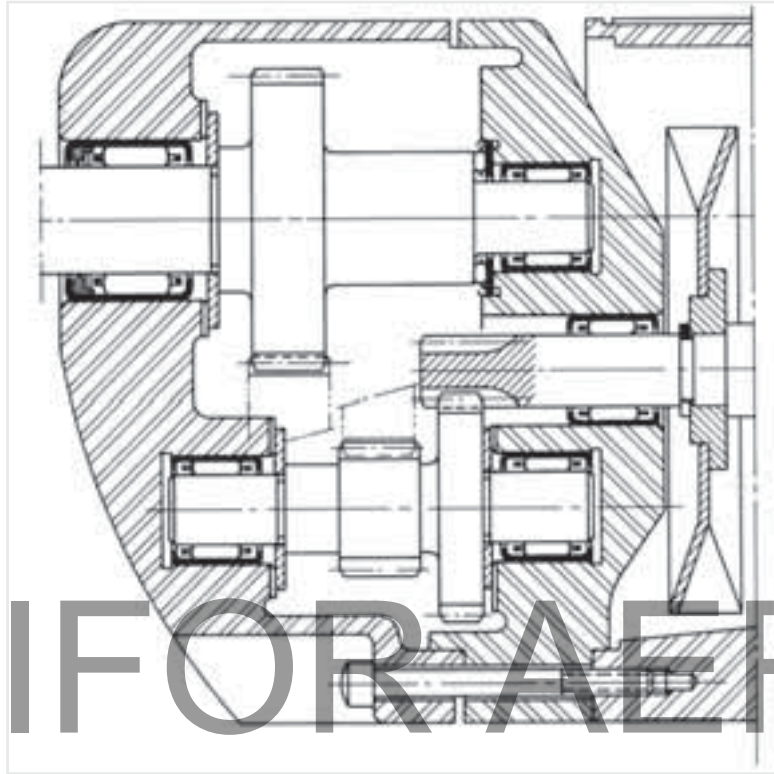

# ADIFOR AERO

This example shows the use, on a hardened shaft, of type HK caged needle bushes, whose small radial thickness is particularly suitable for this type of application. The

outer bearing of the output shaft is supported by a HK sealed, caged needle bush. Axial drilling loads are carried by a needle thrust bearing type AX.



# Applications

## ROLLING MILL FOLLOWER

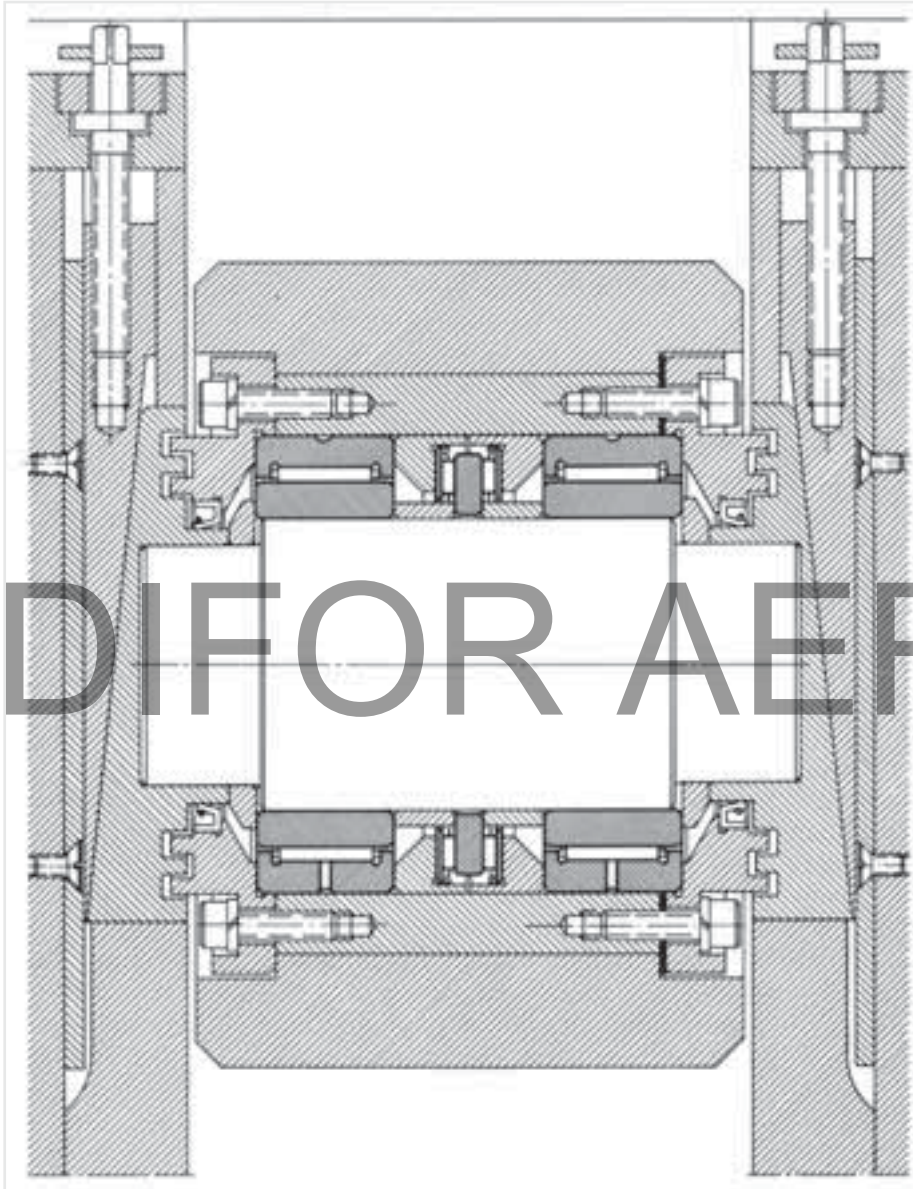

ADIFOR AERO

This roller guides hot rolled steel products whose temperature is around 100°C. A cooling spray limits the temperature of the roller to 50°C. Two NA 3 080 full complement bearing support the radial load which may be as high as 28 000 daN at a speed of 100 r.p.m.

Axial location of the rollers is by two AX needle thrust bearings of 90 mm bore, mounted either side of a CPR intermediate plate. Lip seals and grease filled labyrinths effectively prevent the ingress of coolant into the bearing

# Applications

## GEAR PUMP

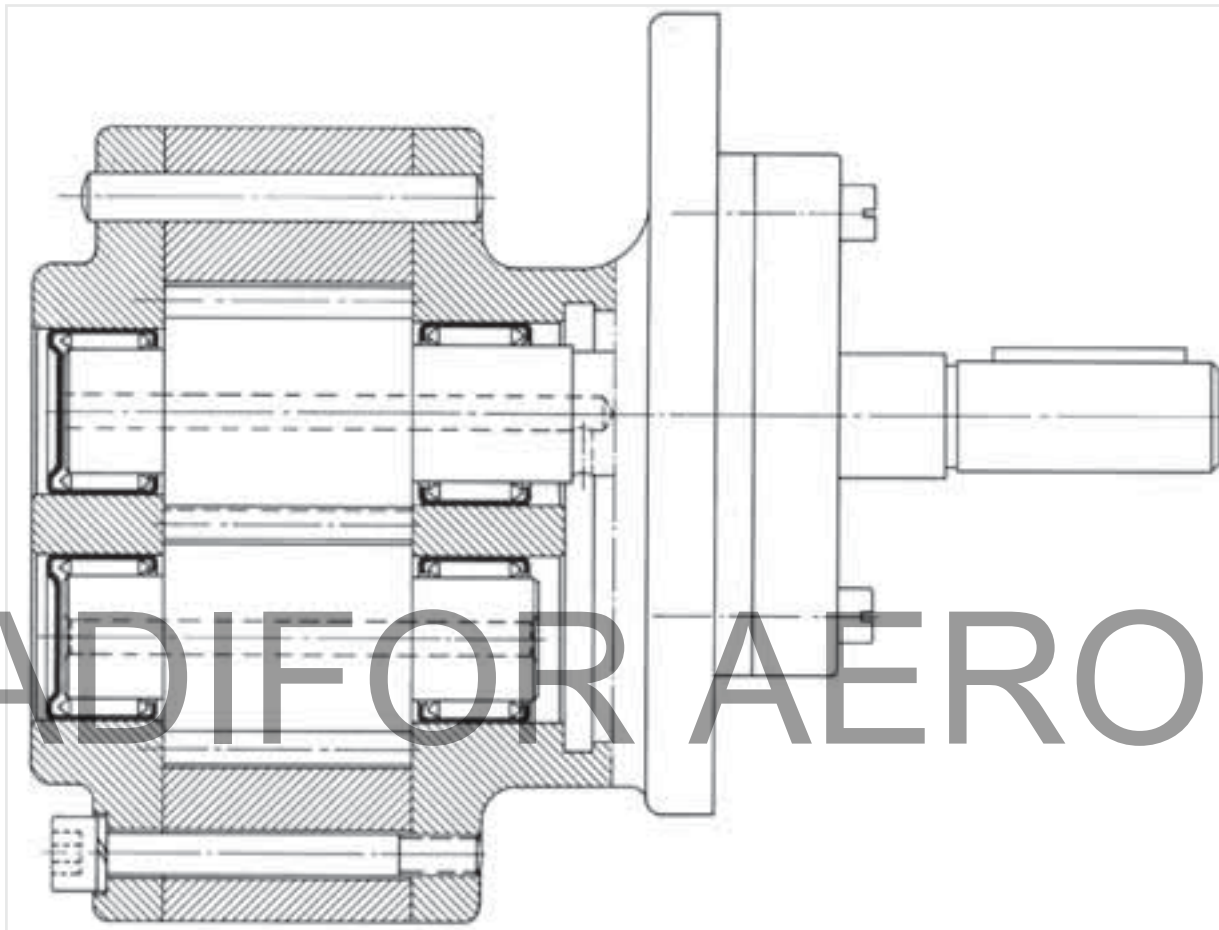

The operating conditions of this gear pump allow the use of DL and DLF full complement needle bushes bearings on the pinion journals. The DLF closed end

needle bushes ensure the sealing of the bores in the bottom plate. The trunnions, acting as raceways under the needles, are hardened to 58 HRC.

# Applications

## WORM AND WHEEL SPEED REDUCER

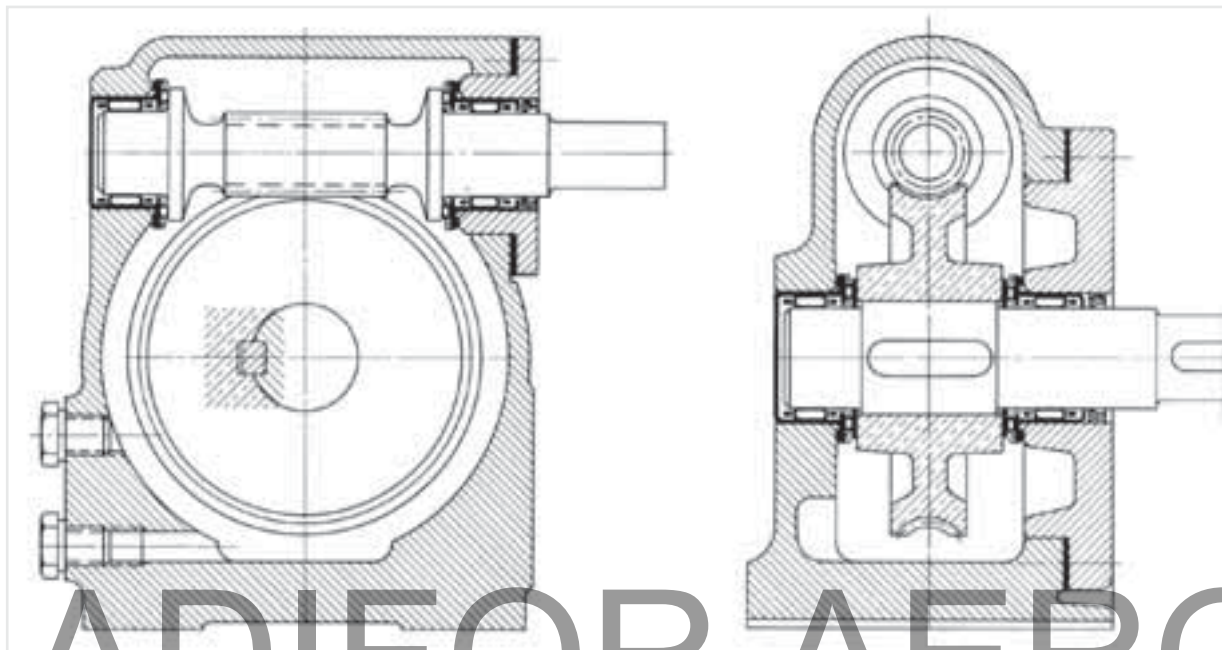

# ADIFOR AERO

The minimal space requirement of the RAX 700 combined bearings has led to the conception of an extremely compact speed reducer with outside dimensions only slightly greater than the size of the gears. As well as achieving economy in the casting, this arrangement also allows minimal bearing span, thereby affording greater rigidity and resistance to possible deflection of the worm.

The input and output shafts are sealed by type DH sealing rings of the same radial dimensions as the corresponding bearings and the opposite ends of the same shaft by means of RAXF 700 closed end combined bearings. The shaft journals serving as bearing raceways are hardened to 58 HRC.

# Applications

## RIGHT-ANGLE GEAR BOX

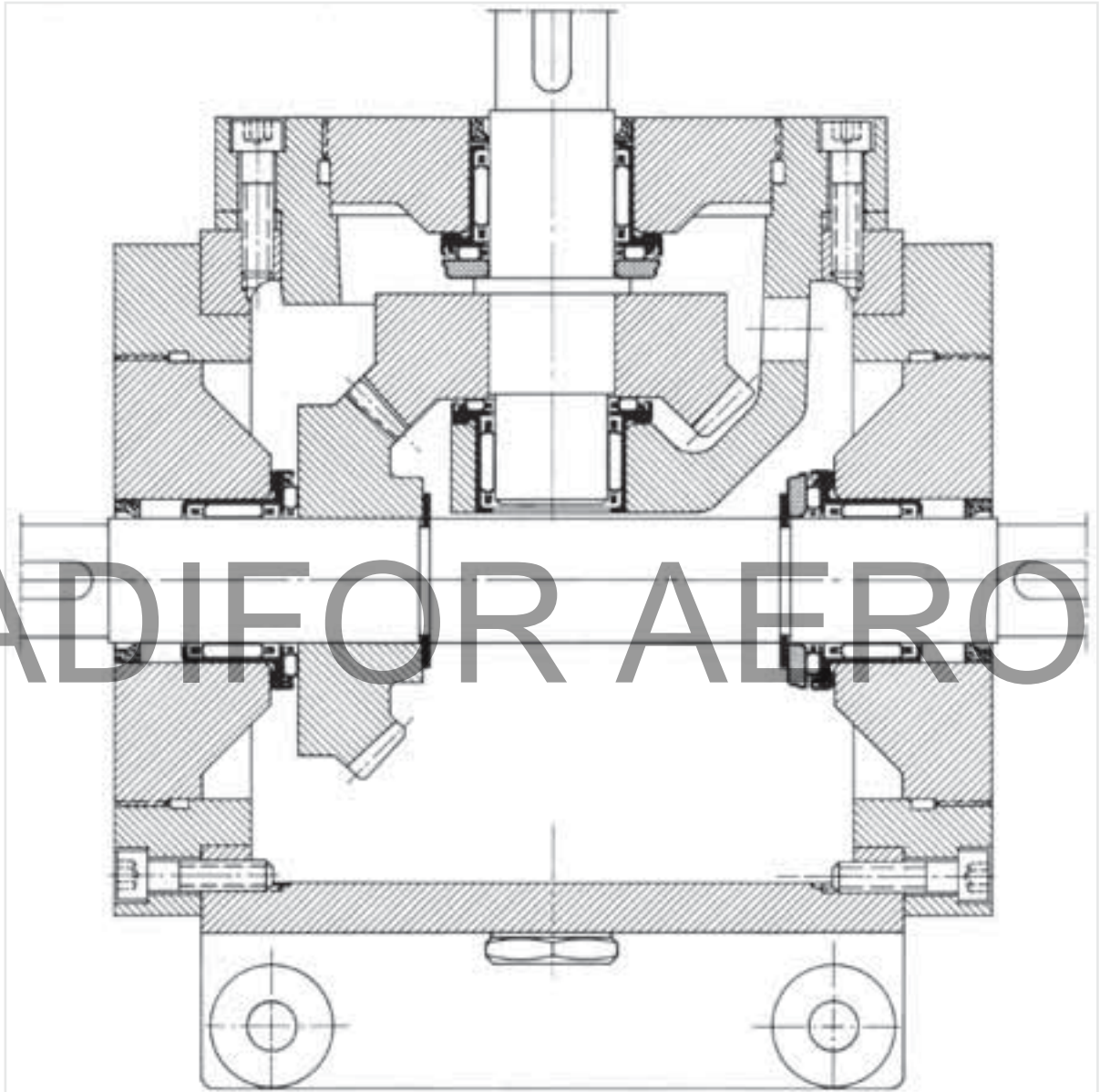

The driving shaft runs in two combined bearings types RAX 718 and RAX 720 with separate thrust plates. The driven shaft is mounted on two RAX 720 combined bearings of which one only has a separate thrust plate. The shaft journals and gear faces serving as bearing raceways are hardened to 58 HRC.

The sealing of all shafts is ensured by type DH 20 26 sealing rings.

# Applications

## "RAPIER" WEAVING MACHINE

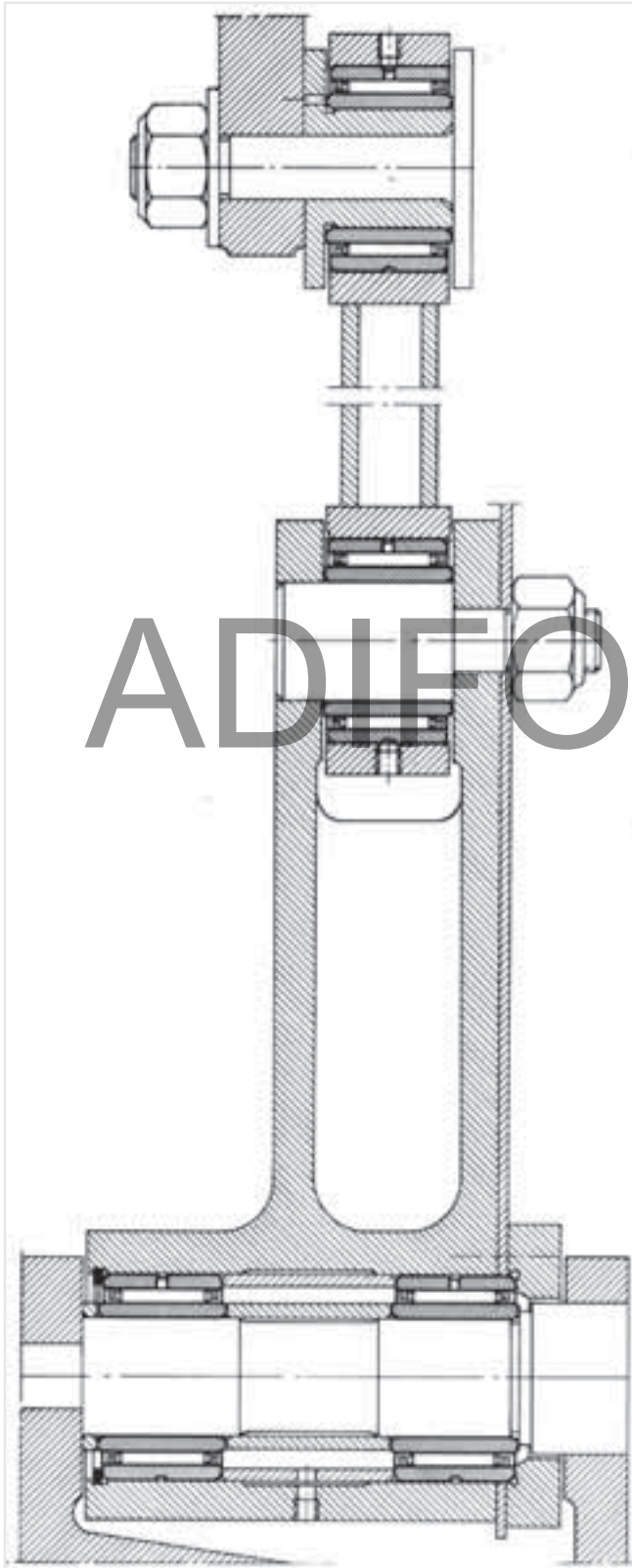

On this type of weaving machine, the shuttles are replaced by "spears" or "rapiers" whose function is to project the weft thread through the warp threads to produce larger widths of cloth. The fore and aft operation of these "rapiers" is by means of a system of connecting rods whose arms are fitted with NA 22 030 full complement needle bearings (with inner races) which fully cater for the shock loadings occasioned by reversals of directions, either rotationally or under oscillating movement.

ADIFOR AERO

# Applications

## DRUM SUPPORT ROLLERS

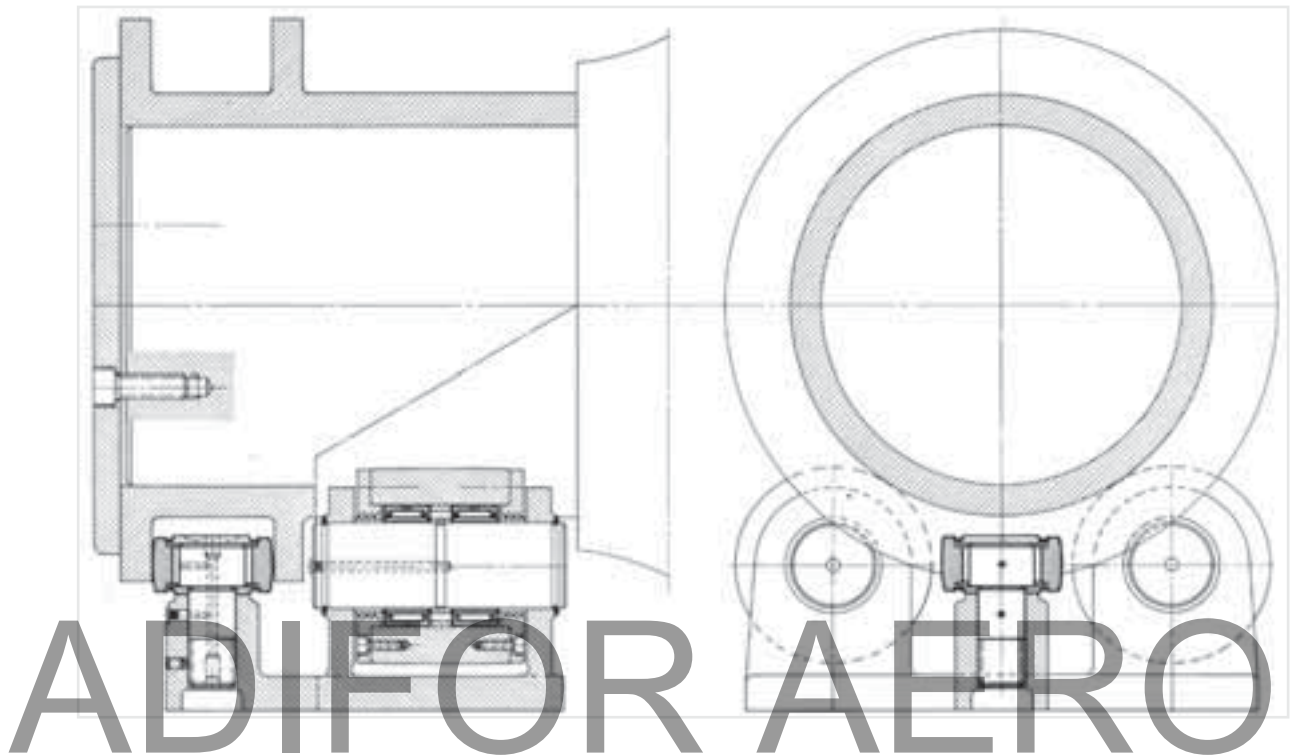

These rollers are each fitted with two NK 42/20 caged needle bearings with inner rings. A GC52EE sealed cam follower with stud mounted vertically between the flanges of the sleeve, ensures lateral location of the cylinder in both directions.

This arrangement offers the following advantages:

- The bearings are determined by the load to be carried rather than by the diameter of the trunnion. It is clearly preferable to use four small bearings, rather than one of unnecessarily large diameter.

- When the drum is heated internally, only a small amount of heat is transferred to the bearings via the outside diameter and the bearings do not have to have specially increased play to allow for expansion of the inner rings, as would be the case with a large bearing mounted on the trunnion.

- Finally the coefficient of friction is much reduced and less power is required to turn the cylinder.

# Applications

## HAND OPERATED VALVE

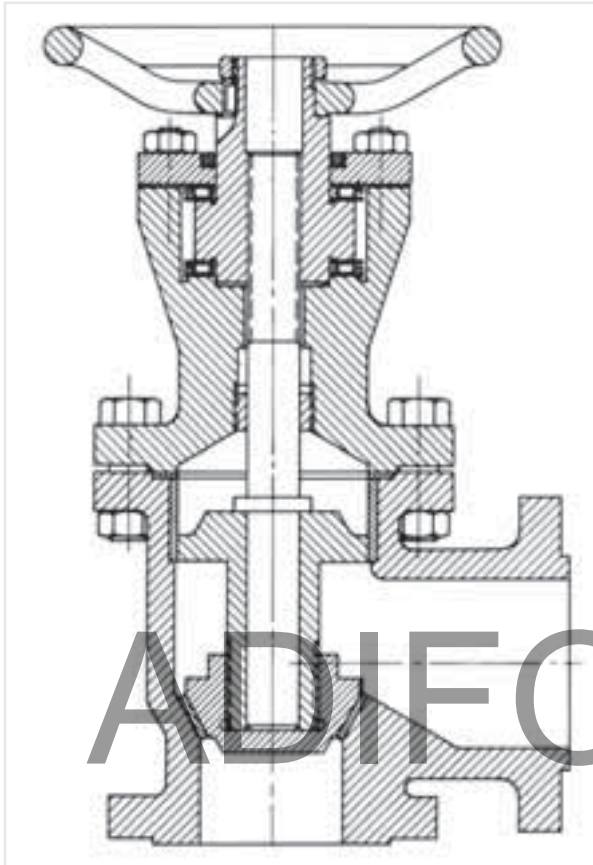

Threaded spindle support mounted between two needle thrust bearings, i.e. AX 45 65 (with matching thrust races) ensures low frictional characteristics and easy manual operation.

# ADIFOR AÉRO



Distributeur de fournitures pour l'industrie aéronautique en Rhône-Alpes  
8 rue du Puits Rochefort Z.I. de Montmartre, 42100 Saint-Étienne, FRANCE  
+33-(0)4 77 49 36 36

