



New Hampshire Ball Bearings, Inc.

— *A Minebea Company* —

Roller and Ball Bearings Design Guide

ADIFOR AÉRO



Distributeur de fournitures pour l'industrie aéronautique en Rhône-Alpes 8
rue du Puits Rochefort Z.I. de Montmartre, 42100 Saint-Étienne, FRANCE
+33-(0)4 77 49 36 36



NHBB

HITECH DIVISION
Roller and Ball Bearings
Design Guide

ADIFOR AERO

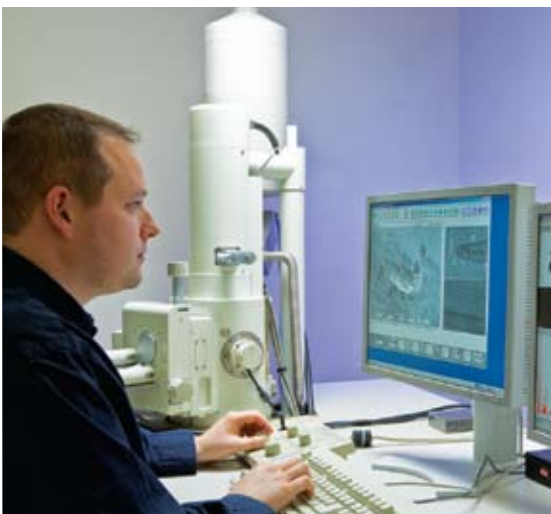

SUPPORTING THE SUCCESS OF OUR CUSTOMERS

Commitment. Knowledge. Vision.

At NHBB, we know that a strong supplier relationship begins with an unequivocal commitment to addressing the needs of our customers. We demonstrate this commitment every day with our ability to respond to the complex performance requirements of components used in critical applications in a competitive marketplace.

It's also about the value of collaboration. The products we supply typically evolve from a customer concept where requirements and specifications are defined and developed throughout the process. Being closely involved during the development phase, and continually responding to the many challenges that occur throughout the production years, clearly defines our business approach.

At NHBB, we've been evolving in a consistent direction for many years, instructed by experiences that have added to our strong technical foundation. That knowledge enables us to continually advance our expertise in efficiency, quality, and innovation, and it provides the opportunity to reinforce our position in the global aerospace supply chain. And while we've reached a significant level of capability and expertise, we continually strive to meet the ever-changing challenges of designing and producing high value, complex products.

Such persistence is supported by a constant investment in our facility and our technical capabilities. From state-of-the-art machine centers for milling tight tolerance components and grinding complex features, to advanced heat-treatment equipment, to rigorous in-process quality control protocols, and to a certified clean room for assembly, our factory reflects a long-term commitment to aligning our capacity and our capabilities to the current and future needs of our customers.

We invite you to review our design guide. It is intended to be just one part of the total resource package we provide to our customers in support of their success. This guide represents a starting point for a variety of the concepts and considerations necessary to initiate a bearing design, and it reinforces our readiness to work together to find the best solutions possible.

Capabilities

PRODUCTS

- Complex ball and roller bearings
- Bearing sizes through 300 mm O.D.
- Cylindrical roller bearings
- Ball bearings
 - Angular contact
 - Gothic arch
 - Duplex/super duplex
 - Torque tube
 - Thin section



QUALITY CERTIFICATIONS

- ISO 9001:2000
- AS9100, Rev B
- Boeing D6-82479
- Nadcap:
 - AC7102 – Heat-treating – including carburizing
 - AC7108 – Chemical processing – including passivation
 - AC7114 – Nondestructive testing



ENVIRONMENTAL MANAGEMENT CERTIFICATION

- ISO 14001:2004



Introduction

06 Part Numbering System

Cylindrical Roller Bearings, Metric Series

09 Bore Sizes 10-25 mm

10 Bore Sizes 30-55 mm

11 Bore Sizes 60-85 mm

12 Bore Sizes 90-130 mm

13 Bore Sizes 140-200 mm

Ball Bearings, Metric Series

Radial

15 Bore Sizes 10-25 mm

16 Bore Sizes 30-55 mm

17 Bore Sizes 60-85 mm

18 Bore Sizes 90-130 mm

19 Bore Sizes 140-200 mm

Angular Contact

20 Bore Sizes 10-25 mm

21 Bore Sizes 30-55 mm

22 Bore Sizes 60-85 mm

23 Bore Sizes 90-130 mm

24 Bore Sizes 140-200 mm

Ball Bearings, Inch Series

25 Radial

26 Torque Tube - Radial

27 Torque Tube - Angular Contact

28 Thin Section - Radial and Gothic Arch

30 Thin Section - Angular Contact

Special Products

33 Complex Bearing Assemblies with Customized Features

ADI FOR AERO



Engineering

37	Materials
39	Internal Bearing Geometry
43	Roller Bearing Features
44	Load Ratings and Bearing Life
46	Preload and Duplex Bearings
48	Shaft and Housing Fits
52	Seals and Shields
53	Cage Types
56	Lubrication
56	Platings and Coatings
58	Tolerances
59	Ball Grades
59	Silicon Nitride Balls
60	Engineering Analysis and Reporting
61	Temperature Conversion Table
62	Inch/Metric Conversion Table

ADI FOR AERO

New Hampshire Ball Bearings, Inc.

63	Company Overview
64	Astro Division, Laconia, NH
65	Precision Division, Chatsworth, CA
66	myonic USA, Chatsworth, CA
67	Minebea Co., Ltd.

NHBB reserves the right to change specifications and other information included in this catalog without notice. All information, data and dimension tables in this catalog have been carefully compiled and thoroughly checked and are provided on an "as is" basis for informational purposes only. NHBB assumes no responsibility and/or liability whatsoever for any errors or omissions in these materials.

All materials in this catalog are protected by copyright laws and may not be reproduced, republished, or otherwise exploited in any manner without the express written permission of NHBB. NHBB names, logos and all related trademarks, tradenames, and other intellectual property (including NHBB part numbers, series numbers, and the like) are the property of NHBB and cannot be used without NHBB's express written permission.

Part Numbering System

Cylindrical Roller Bearings

EXAMPLE: MTPULS105-5

MT	TP	U	L	S	105	-5
MATERIAL	ALL ROLLERS	OUTER RING CONFIGURATION	INNER RING CONFIGURATION	CAGE MATERIAL	BASIC SIZE	- DASH NUMBER
No Code=52100 chrome steel	TP	U =Double guide flange	U =Double guide flange	B =Bronze or brass S =Steel	ABMA dimension series 18, 19, 10, 02 and 03 indicated by 18, 19, 1, 2 and 3 followed by bore size of: 00 for 10 mm 01 for 12 mm 02 for 15 mm 03 for 17 mm 04 for 20 mm 05 for 25 mm etc. ... in 5 mm increments	Unique number assigned within each dimension series identifying special features
MT =M50 tool steel		L =Single guide flange	L =Single guide flange			
SB =BG42®		S =No guide flanges	S =No guide flanges			
SS =440C stainless steel						

ADIFOR AERO

The roller bearing part numbering system is designed to identify the important basic features of the bearing while providing a unique part number. Complete bearing details are available on NHBB sales drawings.

Part Numbering System

Ball Bearings

EXAMPLE: MTMER-1905SDXXXDB20R6A5

MT	MER-	1905		SDXXX	DB20	R6	A5
MATERIAL	TYPE	BASIC NUMBER	CLOSURES	SPECIAL DESIGN	DUPLEX	CAGES	TOLERANCE
No Code=52100 chrome steel	F =Flanged	Inch Series:	D =Rubber seal	SD _ _ _ ,	DB =Back to back	F =None, full complement	A1 =ABEC 1*
CE =52100 rings, ceramic balls	GR =Gothic arch	First 1-3 digits indicate O.D. in 16ths of an inch, the bore size is the next 2-3 digits	DD1 =Molded, snap-in seal	3 digit number assigned by NHBB	DF =Face to face	R =Two-piece ribbon, steel	A3 =ABEC 3
MT =M50 tool steel	R,RI =Radial	Metric Series: ABMA	H =Metallic shield	engineering, denotes special design features	DT =Tandem	A5 =ABEC 5	A7 =ABEC 7
SB =BG42®	RW =Radial with cartridge width	Dimension series 18, 19, 10, 02 and 03 indicated by 18, 19, 1, 2 and 3 followed by bore size of:	L =Glass reinforced PTFE shield		DU =Universal	R6 =Riveted ribbon, steel	A9 =ABEC 9
SE =440C rings, ceramic balls	MBR =Inner ring relieved, separable	00 for 10 mm	S =Noncontact rubber seal		The number following the 2 digit alpha code (e.g. DB) equals preload value in pounds	B2 =Two-piece riveted, bronze	*A1 miniature and instrument bearings of both the metric and inch configurations meet the tolerances of ABMA Standard 20 for ABEC 1 metric series bearings
SH =Cobalt based alloy	MDR =Inner ring relieved, nonseparable	01 for 12 mm	Z =Metallic shield, removable			B5 =Machined, silicon-iron bronze	
SS =440C stainless steel	MER =Outer ring relieved, nonseparable	02 for 15 mm				KE =Crown, inner land piloted, phenolic	
TE =M50 rings, ceramic balls	W =Fractured outer ring	03 for 17 mm				KM =Fully machined, inner land piloted, phenolic	
		04 for 20 mm				M2 =One-piece machined, silver plated steel	
		05 for 25 mm					
		etc. ... in 5 mm increments					

The above descriptions indicate the most common options; additional types exist. Beyond the basic **part number**, NHBB may also show **specifications** such as coding, radial play, torque, lubricant and packaging. These features are not part of the basic number.

ADIFOR AERO



Metric Series

Bore Sizes 10-25 mm

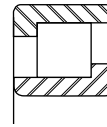
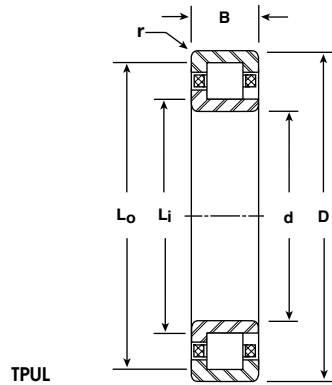

TPLL

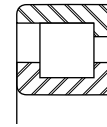

TPLU

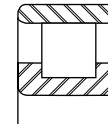

TPSU

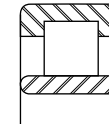

TPUS

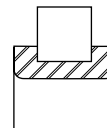

TPU inner

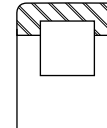

TPU outer

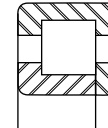

TPUU

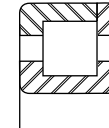

TPUU

BASIC P/N	BORE d		O.D. D		WIDTH B		NOMINAL ROLLER PATH DIA.		MOUNTING SHOULDER DIA.		FILLET RADIUS r	ROLLER		LOAD RATINGS LBS	
	mm	INCH	mm	INCH	mm	INCH	INNER	OUTER	MIN. SHAFT Li	MAX. HOUSING Lo		NO.	DIA. & LENGTH mm	DYN. C	STATIC Co
							INCH	INCH	INCH	INCH					
TP1900	10	.3937	22	.8661	6	.2362	.4923	.7679	.472	.788	.012	10	3.5	1100	790
TP100	10	.3937	26	1.0236	8	.3150	.5116	.9053	.482	.929	.012	8	5	1800	1250
TP200	10	.3937	30	1.1811	9	.3543	.5910	.9847	.558	1.025	.024	8	5	1800	1250
TP300	10	.3937	35	1.3780	11	.4331	.6694	1.1812	.571	1.202	.024	8	6.35	2900	2000
TP1901	12	.4724	24	.9449	6	.2362	.5777	.8532	.559	.862	.012	10	3.5	1100	810
TP101	12	.4724	28	1.1024	8	.3150	.5909	.9846	.560	1.016	.012	8	5	1800	1250
TP201	12	.4724	32	1.2598	10	.3937	.6299	1.1024	.616	1.116	.024	8	6	2500	1750
TP301	12	.4724	37	1.4567	12	.4724	.7103	1.2615	.676	1.263	.039	8	7	3400	2400
TP1902	15	.5906	28	1.1024	7	.2756	.7088	.9844	.678	1.027	.012	14	3.5	1400	1200
TP102	15	.5906	32	1.2598	9	.3543	.7382	1.1319	.682	1.166	.012	10	5	2150	1650
TP202	15	.5906	35	1.3780	11	.4331	.7485	1.2210	.737	1.239	.024	10	6	2950	2250
TP302	15	.5906	42	1.6535	13	.5118	.8229	1.4529	.792	1.452	.039	8	8	4400	3200
TP1903	17	.6693	30	1.1811	7	.2756	.7877	1.0633	.742	1.107	.012	14	3.5	1400	1200
TP103	17	.6693	35	1.3780	10	.3937	.8366	1.2303	.767	1.288	.012	12	5	2450	2050
TP203	17	.6693	40	1.5748	12	.4724	.8782	1.3900	.811	1.425	.024	10	6.35	3600	2850
TP303	17	.6693	47	1.8504	14	.5512	.9232	1.6319	.872	1.640	.039	8	9	5400	4000
TP1804	20	.7874	32	1.2598	7	.2756	.8858	1.1614	.879	1.172	.012	16	3.5	1550	1400
TP1904	20	.7874	37	1.4567	9	.3543	.9352	1.3289	.878	1.371	.012	14	5	2750	2450
TP104	20	.7874	42	1.6535	12	.4724	.9449	1.4961	.922	1.519	.024	10	7	4000	3250
TP204	20	.7874	47	1.8504	14	.5512	1.0199	1.6498	.975	1.667	.039	10	8	5200	4250
TP304	20	.7874	52	2.0472	15	.5906	1.0235	1.8109	.994	1.849	.039	8	10	6650	5050
TP1805	25	.9843	37	1.4567	7	.2756	1.0847	1.3583	1.060	1.380	.012	18	3.5	1700	1600
TP1905	25	.9843	42	1.6535	9	.3543	1.1429	1.5366	1.075	1.569	.012	16	5	3050	2850
TP105	25	.9843	47	1.8504	12	.4724	1.1419	1.6931	1.131	1.702	.024	12	7	4600	4050
TP205	25	.9843	52	2.0472	15	.5906	1.2003	1.8303	1.151	1.861	.039	12	8	5950	5300
TP305	25	.9843	62	2.4409	17	.6693	1.3211	2.1873	1.206	2.223	.039	10	11	9300	7750

Notes:

- NHBB typically manufactures roller bearings in both 52100 and M50 material to ABEC 5 tolerances per ABMA Standard 20. Other materials and tolerances are available.
- All cages are metallic and one-piece machined.
- Standard rollers have equal length and diameter. Rectangular rollers, typically under a 2:1 length-to-diameter ratio, are also available.
- Custom features such as puller grooves, mounting flanges and anti-rotation devices can be designed into all ring configurations.
- Fillet Radius (r) is the maximum shaft or housing fillet radius that bearing corners will clear.



Metric Series

Bore Sizes 30-55 mm

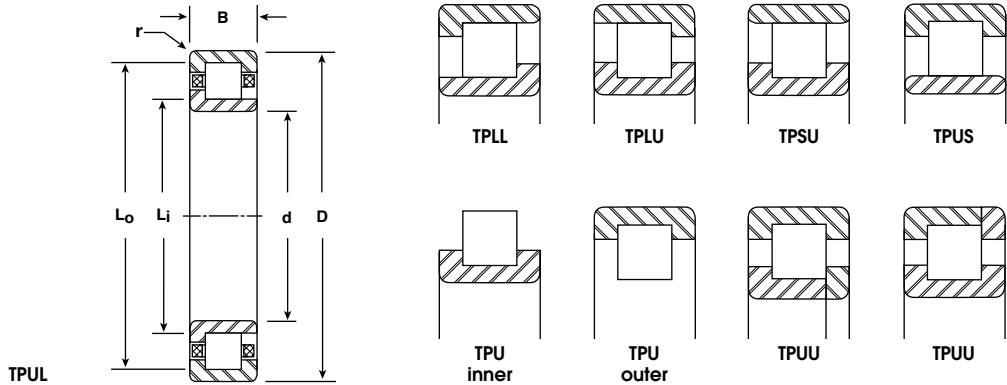

BASIC P/N	BORE d		O.D. D		WIDTH B		NOMINAL ROLLER PATH DIA.		MOUNTING SHOULDER DIA.		FILLET RADIUS r	ROLLER		LOAD RATINGS LBS	
	mm	INCH	mm	INCH	mm	INCH	INNER	OUTER	MIN. SHAFT Li	MAX. HOUSING Lo		NO.	DIA. & LENGTH mm	DYN. C	STATIC Co
							INCH	INCH	INCH	INCH					
TP1806	30	1.1811	42	1.6535	7	.2756	1.2795	1.5551	1.255	1.589	.012	20	3.5	1800	1800
TP1906	30	1.1811	47	1.8504	9	.3543	1.3288	1.7225	1.265	1.765	.012	18	5	3300	3300
TP106	30	1.1811	55	2.1654	13	.5118	1.4116	1.9628	1.360	1.985	.039	14	7	5150	4900
TP206	30	1.1811	62	2.4409	16	.6299	1.4579	2.2454	1.375	2.285	.039	12	10	9050	8150
TP306	30	1.1811	72	2.8346	19	.7480	1.5219	2.5455	1.415	2.600	.039	10	13	12900	11100
TP1807	35	1.3780	47	1.8504	7	.2756	1.4764	1.7520	1.450	1.770	.012	22	3.5	1950	2050
TP1907	35	1.3780	55	2.1654	10	.3937	1.5470	2.0195	1.517	2.030	.024	18	6	4550	4650
TP107	35	1.3780	62	2.4409	14	.5512	1.6100	2.2400	1.562	2.257	.039	14	8	6700	6500
TP207	35	1.3780	72	2.8346	17	.6693	1.6946	2.5607	1.585	2.624	.039	12	11	10700	9900
TP307	35	1.3780	80	3.1496	21	.8268	1.7126	2.8150	1.685	2.846	.059	10	14	14700	12900
TP1808	40	1.5748	52	2.0472	7	.2756	1.6735	1.9491	1.650	1.960	.012	24	3.5	2100	2250
TP1908	40	1.5748	62	2.4409	12	.4724	1.7327	2.2839	1.708	2.302	.024	18	7	6200	6500
TP108	40	1.5748	68	2.6772	15	.5906	1.7718	2.4805	1.758	2.499	.039	14	9	8250	8100
TP208	40	1.5748	80	3.1496	18	.7087	1.9130	2.8579	1.795	2.933	.039	12	12	12600	12000
TP308	40	1.5748	90	3.5433	23	.9055	1.9607	3.2206	1.890	3.243	.059	10	16	19100	17100
TP1809	45	1.7717	58	2.2835	7	.2756	1.8899	2.1655	1.875	2.190	.012	28	3.5	2350	2650
TP1909	45	1.7717	68	2.6772	12	.4724	1.9486	2.4998	1.912	2.537	.024	20	7	6750	7300
TP109	45	1.7717	75	2.9528	16	.6299	2.0258	2.7344	1.957	2.760	.039	16	9	9100	9450
TP209	45	1.7717	85	3.3465	19	.7480	2.0725	3.0962	1.980	3.135	.039	12	13	14800	14300
TP309	45	1.7717	100	3.9370	25	.9843	2.1852	3.5238	2.080	3.625	.059	10	17	21500	19700
TP1810	50	1.9685	65	2.5591	7	.2756	2.1260	2.4016	2.102	2.395	.012	32	3.5	2600	3050
TP1910	50	1.9685	72	2.8346	12	.4724	2.1267	2.6779	2.107	2.696	.024	20	7	6750	7400
TP110	50	1.9685	80	3.1496	16	.6299	2.2227	2.9314	2.152	2.963	.039	18	9	9950	10700
TP210	50	1.9685	90	3.5433	20	.7874	2.2698	3.2934	2.183	3.334	.039	14	13	16600	16900
TP310	50	1.9685	110	4.3307	27	1.0630	2.4393	3.9353	2.357	3.949	.079	10	19	26600	24900
TP1811	55	2.1654	72	2.8346	9	.3543	2.3031	2.6969	2.281	2.720	.012	30	5	4850	5850
TP1911	55	2.1654	80	3.1496	13	.5118	2.3956	2.9467	2.361	2.953	.039	24	7	7700	9000
TP111	55	2.1654	90	3.5433	18	.7087	2.4427	3.3088	2.396	3.314	.039	16	11	13200	14100
TP211	55	2.1654	100	3.9370	21	.8268	2.5004	3.6028	2.444	3.654	.059	14	14	18900	19600
TP311	55	2.1654	120	4.7244	29	1.1417	2.7343	4.2304	2.555	4.334	.079	12	19	30500	30600

Notes:

- NHBB typically manufactures roller bearings in both 52100 and M50 material to ABEC 5 tolerances per ABMA Standard 20. Other materials and tolerances are available.
- All cages are metallic and one-piece machined.
- Standard rollers have equal length and diameter. Rectangular rollers, typically under a 2:1 length-to-diameter ratio, are also available.
- Custom features such as puller grooves, mounting flanges and anti-rotation devices can be designed into all ring configurations.
- Fillet Radius (r) is the maximum shaft or housing fillet radius that bearing corners will clear.



Metric Series

Bore Sizes 60-85 mm



TPUL

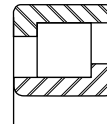
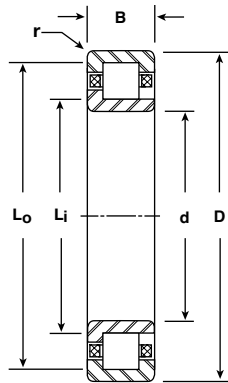

TPLL

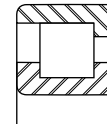

TPLU

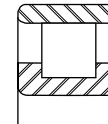

TPSU

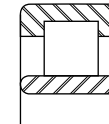

TPUS

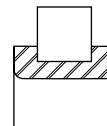

TPU inner

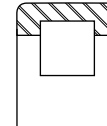

TPU outer

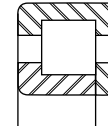

TPUU

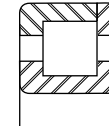

TPUU

BASIC P/N	BORE d		O.D. D		WIDTH B		NOMINAL ROLLER PATH DIA.		MOUNTING SHOULDER DIA.		FILLET RADIUS r	ROLLER		LOAD RATINGS LBS	
	mm	INCH	mm	INCH	mm	INCH	INNER INCH	OUTER INCH	MIN. SHAFT Li INCH	MAX. HOUSING Lo INCH		NO.	DIA. & LENGTH mm	DYN. C	STATIC Co
											mm				
TP1812	60	2.3622	78	3.0709	10	.3937	2.5196	2.9134	2.480	2.940	.012	32	5	5100	6250
TP1912	60	2.3622	85	3.3465	13	.5118	2.5873	3.1385	2.565	3.145	.039	22	7	7250	8300
TP112	60	2.3622	95	3.7402	18	.7087	2.6180	3.4841	2.597	3.515	.039	18	11	14400	16000
TP212	60	2.3622	110	4.3307	22	.8661	2.7483	4.0082	2.643	4.046	.059	14	16	24500	25800
TP312	60	2.3622	130	5.1181	31	1.2205	2.9525	4.5273	2.769	4.715	.079	12	20	33700	34400
TP1813	65	2.5591	85	3.3465	10	.3937	2.7166	3.1891	2.670	3.215	.024	28	6	6350	7700
TP1913	65	2.5591	90	3.5433	13	.5118	2.7757	3.3269	2.758	3.345	.039	26	7	8200	9850
TP113	65	2.5591	100	3.9370	18	.7087	2.8152	3.6813	2.783	3.707	.039	18	11	14400	16200
TP213	65	2.5591	120	4.7244	23	.9055	3.0432	4.3030	2.855	4.429	.059	14	16	24500	26300
TP313	65	2.5591	140	5.5118	33	1.2992	3.2124	4.9447	2.942	5.124	.079	12	22	40500	41800
TP1814	70	2.7559	90	3.5433	10	.3937	2.9134	3.3858	2.860	3.410	.024	30	6	6700	8250
TP1914	70	2.7559	100	3.9370	16	.6299	3.0095	3.7182	2.965	3.737	.039	24	9	12300	14900
TP114	70	2.7559	110	4.3307	20	.7874	3.0314	4.0550	2.995	4.095	.039	18	13	20100	22900
TP214	70	2.7559	125	4.9213	24	.9449	3.1690	4.5076	3.050	4.625	.059	14	17	27600	29800
TP314	70	2.7559	150	5.9055	35	1.3780	3.4332	5.3229	3.199	5.468	.079	12	24	47000	48700
TP1815	75	2.9528	95	3.7402	10	.3937	3.1103	3.5827	3.095	3.600	.024	32	6	7050	8850
TP1915	75	2.9528	105	4.1339	16	.6299	3.1893	3.8979	3.162	3.928	.039	24	9	12300	15000
TP115	75	2.9528	115	4.5276	20	.7874	3.2285	4.2522	3.192	4.295	.039	18	13	20100	23100
TP215	75	2.9528	130	5.1181	25	.9843	3.3269	4.7448	3.256	4.822	.059	14	18	30500	33100
TP315	75	2.9528	160	6.2992	37	1.4567	3.6537	5.7009	3.401	5.847	.079	12	26	53900	56200
TP1816	80	3.1496	100	3.9370	10	.3937	3.3071	3.7795	3.285	3.800	.024	34	6	7350	9450
TP1916	80	3.1496	110	4.3307	16	.6299	3.3859	4.0946	3.358	4.127	.039	26	9	13100	16300
TP116	80	3.1496	125	4.9213	22	.8661	3.5238	4.5474	3.386	4.684	.039	20	13	21700	26000
TP216	80	3.1496	140	5.5118	26	1.0236	3.6222	5.0396	3.518	5.145	.079	16	18	33300	37700
TP316	80	3.1496	170	6.6929	39	1.5354	3.9120	6.1168	3.615	6.235	.079	12	28	61700	64800
TP1817	85	3.3465	110	4.3307	13	.5118	3.5670	4.1182	3.540	4.125	.039	34	7	10000	13200
TP1917	85	3.3465	120	4.7244	18	.7087	3.6243	4.4904	3.575	4.502	.039	24	11	17500	21700
TP117	85	3.3465	130	5.1181	22	.8661	3.6810	4.7834	3.595	4.875	.039	20	14	24700	29700
TP217	85	3.3465	150	5.9055	28	1.1024	3.8777	5.4525	3.722	5.535	.079	14	20	36600	40400
TP317	85	3.3465	180	7.0866	41	1.6142	4.1141	6.3188	3.878	6.558	.098	12	28	62200	66600

Notes:

- NHBB typically manufactures roller bearings in both 52100 and M50 material to ABEC 5 tolerances per ABMA Standard 20. Other materials and tolerances are available.
- All cages are metallic and one-piece machined.
- Standard rollers have equal length and diameter. Rectangular rollers, typically under a 2:1 length-to-diameter ratio, are also available.
- Custom features such as puller grooves, mounting flanges and anti-rotation devices can be designed into all ring configurations.
- Fillet Radius (r) is the maximum shaft or housing fillet radius that bearing corners will clear.



Metric Series

Bore Sizes 90-130 mm

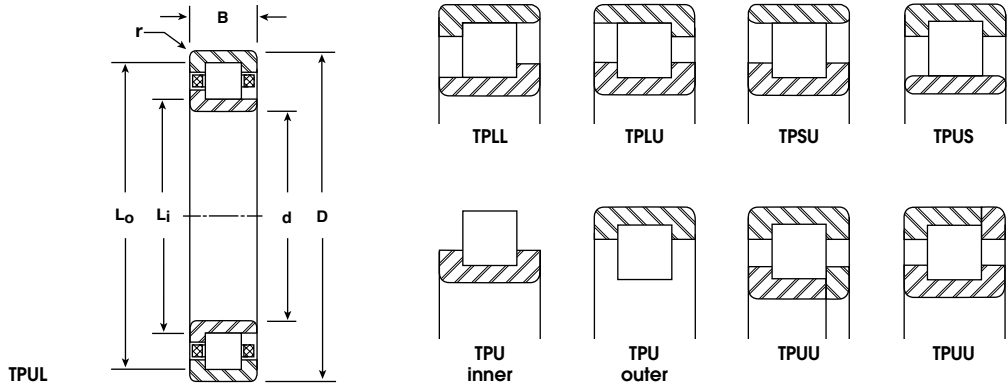

BASIC P/N	BORE d		O.D. D		WIDTH B		NOMINAL ROLLER PATH DIA.		MOUNTING SHOULDER DIA.		FILLET RADIUS r	ROLLER		LOAD RATINGS LBS	
	mm	INCH	mm	INCH	mm	INCH	INNER	OUTER	MIN. SHAFT Li	MAX. HOUSING Lo		NO.	DIA. & LENGTH mm	DYN. C	STATIC Co
							INCH	INCH	INCH	INCH					
TP1818	90	3.5433	115	4.5276	13	.5118	3.7603	4.3115	3.740	4.360	.039	36	7	10500	14000
TP1918	90	3.5433	125	4.9213	18	.7087	3.8213	4.6874	3.762	4.693	.039	24	11	17900	22400
TP118	90	3.5433	140	5.5118	24	.9449	3.9668	5.1479	3.840	5.215	.059	20	15	27800	33700
TP218	90	3.5433	160	6.2992	30	1.1811	4.1336	5.7085	3.979	5.870	.079	16	20	40400	46800
TP318	90	3.5433	190	7.4803	43	1.6929	4.3899	6.7521	4.087	6.934	.098	12	30	70100	75300
TP1819	95	3.7402	120	4.7244	13	.5118	3.9567	4.5079	3.920	4.530	.039	38	7	10900	14800
TP1919	95	3.7402	130	5.1181	18	.7087	4.0181	4.8843	3.969	4.902	.039	26	11	19000	24400
TP119	95	3.7402	145	5.7087	24	.9449	4.1263	5.3861	4.033	5.411	.059	20	16	31200	37900
TP219	95	3.7402	170	6.6929	32	1.2598	4.3934	6.1257	4.184	6.257	.079	16	22	48200	56200
TP319	95	3.7402	200	7.8740	45	1.7717	4.6100	7.1297	4.297	7.325	.098	12	32	78900	85200
TP1820	100	3.9370	125	4.9213	13	.5118	4.1533	4.7044	4.140	4.770	.039	40	7	11300	15700
TP1920	100	3.9370	140	5.5118	20	.7874	4.2518	5.1966	4.179	5.278	.039	24	12	21300	27100
TP120	100	3.9370	150	5.9055	24	.9449	4.3225	5.5824	4.238	5.614	.059	20	16	31600	38800
TP220	100	3.9370	180	7.0866	34	1.3386	4.5279	6.4964	4.392	6.637	.079	14	25	56100	63600
TP1821	105	4.1339	130	5.1181	13	.5118	4.3613	4.9125	4.350	4.932	.039	42	7	11700	16500
TP1921	105	4.1339	145	5.7087	20	.7874	4.4489	5.3938	4.361	5.475	.039	24	12	20900	26500
TP121	105	4.1339	160	6.2992	26	1.0236	4.5804	5.9190	4.523	5.968	.079	20	17	34700	42700
TP221	105	4.1339	190	7.4803	36	1.4173	4.8344	6.8817	4.607	7.014	.079	14	26	60500	69300
TP1822	110	4.3307	140	5.5118	16	.6299	4.5681	5.2767	4.560	5.300	.039	34	9	15600	21200
TP1922	110	4.3307	150	5.9055	20	.7874	4.6453	5.5901	4.560	5.670	.039	26	12	22200	28800
TP122	110	4.3307	170	6.6929	28	1.1024	4.7634	6.2594	4.725	6.294	.079	18	19	40400	49200
TP222	110	4.3307	200	7.8740	38	1.4961	5.0002	7.2049	4.810	7.391	.079	14	28	70400	81500
TP1824	120	4.7244	150	5.9055	16	.6299	4.9636	5.6722	4.940	5.700	.039	38	9	17400	24600
TP1924	120	4.7244	165	6.4961	22	.8661	5.0867	6.1891	4.960	6.250	.039	26	14	29600	39100
TP124	120	4.7244	180	7.0866	28	1.1024	5.1946	6.6906	5.125	6.738	.079	20	19	43200	54400
TP224	120	4.7244	215	8.4646	40	1.5748	5.4726	7.8348	5.203	7.980	.079	14	30	79300	92600
TP1826	130	5.1181	165	6.4961	18	.7087	5.4140	6.2014	5.390	6.240	.039	36	10	20100	38300
TP1926	130	5.1181	180	7.0866	24	.9449	5.5117	6.6928	5.457	6.750	.059	26	15	33900	45500
TP126	130	5.1181	200	7.8740	33	1.2992	5.7082	7.2830	5.530	7.450	.079	20	20	47800	61200
TP226	130	5.1181	230	9.0551	40	1.5748	5.9643	8.3265	5.693	8.472	.098	16	30	87000	106500

Notes:

- NHBB typically manufactures roller bearings in both 52100 and M50 material to ABEC 5 tolerances per ABMA Standard 20. Other materials and tolerances are available.
- All cages are metallic and one-piece machined.
- Standard rollers have equal length and diameter. Rectangular rollers, typically under a 2:1 length-to-diameter ratio, are also available.
- Custom features such as puller grooves, mounting flanges and anti-rotation devices can be designed into all ring configurations.
- Fillet Radius (r) is the maximum shaft or housing fillet radius that bearing corners will clear.



Metric Series

Bore Sizes 140-200 mm



TPUL

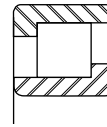
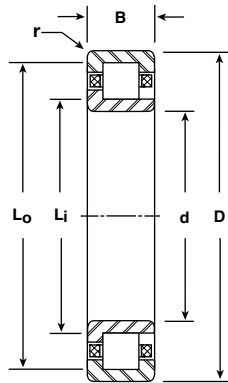

TPLL

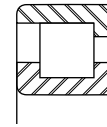

TPLU

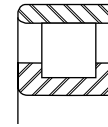

TPSU

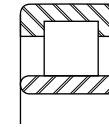

TPUS

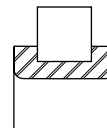

TPU inner

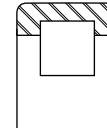

TPU outer

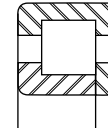

TPUU

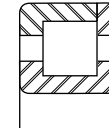

TPUU

BASIC P/N	BORE d		O.D. D		WIDTH B		NOMINAL ROLLER PATH DIA.		MOUNTING SHOULDER DIA.		FILLET RADIUS r	ROLLER		LOAD RATINGS LBS	
	mm	INCH	mm	INCH	mm	INCH	INNER	OUTER	MIN. SHAFT Li	MAX. HOUSING Lo		NO.	DIA. & LENGTH mm	DYN. C	STATIC Co
							INCH	INCH	INCH	INCH					
TP1828	140	5.5118	175	6.8898	18	.7087	5.8072	6.5946	5.760	6.630	.039	38	10	22300	32600
TP1928	140	5.5118	190	7.4803	24	.9449	5.9057	7.0868	5.840	7.140	.059	28	15	36400	50300
TP128	140	5.5118	210	8.2677	33	1.2992	6.1027	7.6775	5.939	7.845	.079	22	20	53100	70800
TP228	140	5.5118	250	9.8425	42	1.6535	6.4176	8.9373	6.132	9.220	.098	16	32	99300	123500
TP1830	150	5.9055	190	7.4803	20	.7874	6.1811	7.2047	6.150	7.244	.039	34	13	32300	46700
TP1930	150	5.9055	210	8.2677	28	1.1024	6.4177	7.7563	6.340	7.825	.079	28	17	46400	65400
TP130	150	5.9055	225	8.8583	35	1.3780	6.5150	8.2479	6.435	8.310	.079	22	22	63800	86100
TP1832	160	6.2992	200	7.8740	20	.7874	6.5748	7.5984	6.530	7.618	.039	34	13	32300	46900
TP1932	160	6.2992	220	8.6614	28	1.1024	6.7710	8.1884	6.720	8.270	.079	28	18	51900	73800
TP132	160	6.2992	240	9.4488	38	1.4961	6.9290	8.8187	6.875	8.880	.079	22	24	74000	105000
TP1834	170	6.6929	215	8.4646	22	.8661	7.0669	8.0905	6.980	8.170	.039	36	13	33700	49900
TP1934	170	6.6929	230	9.0551	28	1.1024	7.1650	8.5824	7.070	8.670	.079	28	18	51900	74100
TP134	170	6.6929	260	10.2362	42	1.6535	7.4407	9.4880	7.380	9.590	.079	22	26	86400	119000
TP1836	180	7.0866	225	8.8583	22	.8661	7.4606	8.4826	7.410	8.540	.039	38	13	35100	52900
TP1936	180	7.0866	250	9.8425	33	1.2992	7.6779	9.2527	7.600	9.350	.079	28	20	63600	92200
TP136	180	7.0866	280	11.0236	46	1.8110	7.8742	10.2364	7.820	10.360	.079	20	30	104500	141500
TP1838	190	7.4803	240	9.4488	24	.9449	7.9134	9.0517	7.840	9.150	.059	36	14	38400	57400
TP1938	190	7.4803	260	10.2362	33	1.2992	8.0703	9.6451	8.030	9.770	.079	28	20	63600	92700
TP138	190	7.4803	290	11.4173	46	1.8110	8.2085	10.7085	8.150	10.830	.079	20	32	117500	160000
TP1840	200	7.8740	250	9.8425	24	.9449	8.3071	9.4094	8.220	9.495	.059	38	14	40000	60800
TP1940	200	7.8740	280	11.0236	38	1.4961	8.5057	10.3937	8.415	10.500	.079	26	24	83900	121500

Notes:

- NHBB typically manufactures roller bearings in both 52100 and M50 material to ABEC 5 tolerances per ABMA Standard 20. Other materials and tolerances are available.
- All cages are metallic and one-piece machined.
- Standard rollers have equal length and diameter. Rectangular rollers, typically under a 2:1 length-to-diameter ratio, are also available.
- Custom features such as puller grooves, mounting flanges and anti-rotation devices can be designed into all ring configurations.
- Fillet Radius (r) is the maximum shaft or housing fillet radius that bearing corners will clear.

ADIFOR AERO

Metric Series

Radial

Bore Sizes 10-25 mm

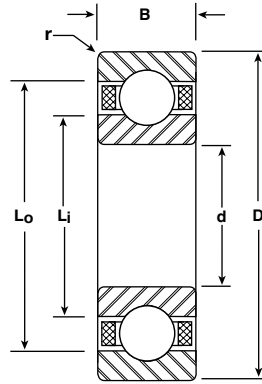

BASIC P/N	BORE d		O.D. D		WIDTH B		LAND DIAMETER (REFERENCE)		FILLET RADIUS r	BALL COMPLEMENT		LOAD RATINGS LBS	
	mm	INCH	mm	INCH	mm	INCH	Li	Lo		NO.	SIZE INCH	DYN. C	STATIC Co
							INCH	INCH					
R-1900	10	.3937	22	.8661	6	.2362	.570	.734	.012	9	1/8	580	280
R-100	10	.3937	26	1.0236	8	.3150	.583	.837	.012	7	3/16	1000	440
R-200	10	.3937	30	1.1811	9	.3543	.656	.919	.024	7	7/32	1300	580
R-300	10	.3937	35	1.3780	11	.4331	.717	1.055	.024	6	9/32	1800	770
R-1901	12	.4724	24	.9449	6	.2362	.629	.800	.012	9	9/64	730	350
R-101	12	.4724	28	1.1024	8	.3150	.670	.900	.012	7	3/16	1000	460
R-201	12	.4724	32	1.2598	10	.3937	.725	1.007	.024	7	15/64	1500	670
R-301	12	.4724	37	1.4567	12	.4724	.777	1.153	.039	6	5/16	2150	930
R-1902	15	.5906	28	1.1024	7	.2756	.735	.972	.012	10	5/32	940	490
R-102	15	.5906	32	1.2598	9	.3543	.803	1.048	.012	9	3/16	1250	630
R-202	15	.5906	35	1.3780	11	.4331	.815	1.153	.024	7	1/4	1700	790
R-302	15	.5906	42	1.6535	13	.5118	.934	1.310	.039	7	5/16	2500	1200
R-1903	17	.6693	30	1.1811	7	.2756	.810	1.032	.012	11	5/32	1000	550
R-103	17	.6693	35	1.3780	10	.3937	.910	1.140	.012	10	3/16	1300	710
R-203	17	.6693	40	1.5748	12	.4724	.952	1.292	.024	8	17/64	2100	1050
R-303	17	.6693	47	1.8504	14	.5512	1.017	1.495	.039	7	11/32	3000	1450
R-1804	20	.7874	32	1.2598	7	.2756	.948	1.098	.012	14	1/8	750	480
R-1904	20	.7874	37	1.4567	9	.3543	.995	1.262	.012	9	7/32	1600	860
R-104	20	.7874	42	1.6535	12	.4724	1.075	1.375	.024	8	1/4	1900	990
R-204	20	.7874	47	1.8504	14	.5512	1.131	1.507	.039	8	5/16	2850	1450
R-304	20	.7874	52	2.0472	15	.5906	1.192	1.643	.043	7	3/8	3550	1750
R-1805	25	.9843	37	1.4567	7	.2756	1.145	1.295	.012	17	1/8	820	600
R-1905	25	.9843	42	1.6535	9	.3543	1.195	1.460	.012	11	7/32	1850	1100
R-105	25	.9843	47	1.8504	12	.4724	1.267	1.567	.024	10	1/4	2200	1300
R-205	25	.9843	52	2.0472	15	.5906	1.328	1.703	.039	9	5/16	3100	1750
R-305	25	.9843	62	2.4409	17	.6693	1.450	1.976	.039	7	15/32	4750	2450

Notes:

1. Metric series radial ball bearings are typically manufactured from 52100 chrome steel to ABEC 3, 5 and 7 tolerances per ABMA Standard 20.
2. Fillet Radius (r) is the maximum shaft or housing fillet radius that bearing corners will clear.

Metric Series

Radial

Bore Sizes 30-55 mm

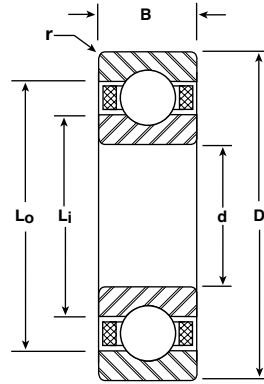

BASIC P/N	BORE d		O.D. D		WIDTH B		LAND DIAMETER (REFERENCE)		FILLET RADIUS r	BALL COMPLEMENT		LOAD RATINGS LBS	
	mm	INCH	mm	INCH	mm	INCH	Li	Lo		NO.	SIZE	DYN. C	STATIC Co
							INCH	INCH	INCH				
R-1806	30	1.1811	42	1.6535	7	.2756	1.342	1.492	.012	20	1/8	880	700
R-1906	30	1.1811	47	1.8504	9	.3543	1.384	1.649	.012	13	7/32	2050	1350
R-106	30	1.1811	55	2.1654	13	.5118	1.504	1.842	.039	11	9/32	2900	1850
R-206	30	1.1811	62	2.4409	16	.6299	1.585	2.037	.039	9	3/8	4350	2500
R-306	30	1.1811	72	2.8346	19	.7480	1.707	2.308	.043	8	1/2	6600	3700
R-1807	35	1.3780	47	1.8504	7	.2756	1.539	1.689	.012	22	1/8	910	760
R-1907	35	1.3780	55	2.1654	10	.3937	1.665	1.942	.024	13	1/4	2600	1750
R-107	35	1.3780	62	2.4409	14	.5512	1.721	2.097	.039	11	5/16	3550	2300
R-207	35	1.3780	72	2.8346	17	.6693	1.824	2.388	.043	8	15/32	5950	3400
R-307	35	1.3780	80	3.1496	21	.8268	1.925	2.602	.059	8	9/16	8200	4700
R-1808	40	1.5748	52	2.0472	7	.2756	1.735	1.886	.012	25	1/8	970	860
R-1908	40	1.5748	62	2.4409	12	.4724	1.857	2.158	.024	14	1/4	2550	1800
R-108	40	1.5748	68	2.6772	15	.5906	1.900	2.351	.039	10	3/8	4650	2950
R-208	40	1.5748	80	3.1496	18	.7087	2.061	2.663	.043	9	1/2	7250	4450
R-308	40	1.5748	90	3.5433	23	.9055	2.183	2.935	.059	8	5/8	9900	5850
R-1809	45	1.7717	58	2.2835	7	.2756	1.953	2.103	.012	28	1/8	1000	950
R-1909	45	1.7717	68	2.6772	12	.4724	2.055	2.393	.024	15	9/32	3450	2650
R-109	45	1.7717	75	2.9528	16	.6299	2.136	2.587	.039	12	3/8	5200	3600
R-209	45	1.7717	85	3.3465	19	.7480	2.277	2.841	.043	9	1/2	7275	4525
R-309	45	1.7717	100	3.9370	25	.9843	2.440	3.268	.059	8	11/16	11800	7100
R-1810	50	1.9685	65	2.5591	7	.2756	2.169	2.357	.012	25	5/32	1400	1295
R-1910	50	1.9685	72	2.8346	12	.4724	2.232	2.570	.024	16	9/32	3600	2850
R-110	50	1.9685	80	3.1496	16	.6299	2.333	2.784	.039	13	3/8	5450	4000
R-210	50	1.9685	90	3.5433	20	.7874	2.455	3.056	.043	10	1/2	7800	5200
R-310	50	1.9685	110	4.3307	27	1.0630	2.698	3.600	.079	8	3/4	13800	8500
R-1811	55	2.1654	72	2.8346	9	.3543	2.387	2.612	.012	23	3/16	1950	1850
R-1911	55	2.1654	80	3.1496	13	.5118	2.469	2.845	.039	16	5/16	4350	3550
R-111	55	2.1654	90	3.5433	18	.7087	2.591	3.117	.043	12	7/16	6900	4950
R-211	55	2.1654	100	3.9370	21	.8268	2.712	3.389	.059	10	9/16	9650	6550
R-311	55	2.1654	120	4.7244	29	1.1417	2.956	3.933	.079	8	13/16	16000	10000

Notes:

- Metric series radial ball bearings are typically manufactured from 52100 chrome steel to ABEC 3, 5 and 7 tolerances per ABMA Standard 20.
- Fillet Radius (r) is the maximum shaft or housing fillet radius that bearing corners will clear.

Metric Series

Radial

Bore Sizes 60-85 mm

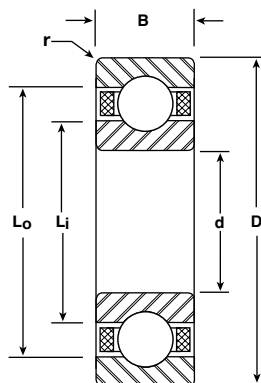

BASIC P/N	BORE d		O.D. D		WIDTH B		LAND DIAMETER (REFERENCE)		FILLET RADIUS r	BALL COMPLEMENT		LOAD RATINGS LBS	
	mm	INCH	mm	INCH	mm	INCH	Li	Lo		NO.	SIZE INCH	DYN. C	STATIC Co
							INCH	INCH					
R-1812	60	2.3622	78	3.0709	10	.3937	2.584	2.848	.012	22	7/32	2600	2400
R-1912	60	2.3622	85	3.3465	13	.5118	2.666	3.042	.039	17	5/16	4500	3800
R-112	60	2.3622	95	3.7402	18	.7087	2.788	3.314	.043	12	7/16	6800	5050
R-212	60	2.3622	110	4.3307	22	.8661	2.970	3.722	.059	10	5/8	11700	8050
R-312	60	2.3622	130	5.1181	31	1.2205	3.213	4.266	.083	8	7/8	18300	11100
R-1813	65	2.5591	85	3.3465	10	.3937	2.821	3.084	.024	23	7/32	2600	2500
R-1913	65	2.5591	90	3.5433	13	.5118	2.863	3.239	.039	18	5/16	4600	4100
R-113	65	2.5591	100	3.9370	18	.7087	2.985	3.511	.043	13	7/16	7100	5550
R-213	65	2.5591	120	4.7244	23	.9055	3.228	4.055	.059	10	11/16	13900	9700
R-313	65	2.5591	140	5.5118	33	1.2992	3.471	4.599	.083	8	15/16	20700	13500
R-1814	70	2.7559	90	3.5433	10	.3937	3.018	3.281	.024	25	7/32	2700	2700
R-1914	70	2.7559	100	3.9370	16	.6299	3.139	3.553	.039	17	11/32	5250	4650
R-114	70	2.7559	110	4.3307	20	.7874	3.242	3.844	.043	13	1/2	9150	7200
R-214	70	2.7559	125	4.9213	24	.9449	3.424	4.252	.059	10	11/16	13900	9850
R-314	70	2.7559	150	5.9055	35	1.3780	3.729	4.932	.083	8	1	23300	15400
R-1815	75	2.9528	95	3.7402	10	.3937	3.214	3.478	.024	26	7/32	2750	2800
R-1915	75	2.9528	105	4.1339	16	.6299	3.317	3.768	.039	17	3/8	5550	6200
R-115	75	2.9528	115	4.5276	20	.7874	3.440	4.041	.043	14	1/2	7800	9500
R-215	75	2.9528	130	5.1181	25	.9843	3.621	4.449	.059	10	11/16	10000	13900
R-315	75	2.9528	160	6.2992	37	1.4567	3.986	5.265	.083	8	1-1/16	17400	26000
R-1816	80	3.1496	100	3.9370	10	.3937	3.411	3.674	.024	28	7/32	2850	3000
R-1916	80	3.1496	110	4.3307	16	.6299	3.514	3.965	.039	17	3/8	5600	6100
R-116	80	3.1496	125	4.9213	22	.8661	3.697	4.373	.043	13	9/16	9100	11300
R-216	80	3.1496	140	5.5118	26	1.0236	3.879	4.782	.079	10	3/4	11900	16200
R-316	80	3.1496	170	6.6929	39	1.5354	4.244	5.598	.083	8	1-1/8	19500	28800
R-1817	85	3.3465	110	4.3307	13	.5118	3.669	4.007	.039	24	9/32	4200	4300
R-1917	85	3.3465	120	4.7244	18	.7087	3.772	4.298	.043	16	7/16	7800	6950
R-117	85	3.3465	130	5.1181	22	.8661	3.893	4.570	.043	13	9/16	11000	9050
R-217	85	3.3465	150	5.9055	28	1.1024	4.137	5.114	.079	10	13/16	18400	13600
R-317	85	3.3465	180	7.0866	41	1.6142	4.539	5.893	.118	8	1-1/8	28500	19600

Notes:

1. Metric series radial ball bearings are typically manufactured from 52100 chrome steel to ABEC 3, 5 and 7 tolerances per ABMA Standard 20.
2. Fillet Radius (r) is the maximum shaft or housing fillet radius that bearing corners will clear.

Metric Series

Radial

Bore Sizes 90-130 mm

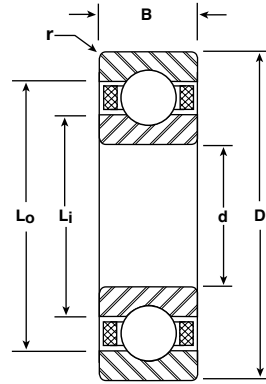

BASIC P/N	BORE d		O.D. D		WIDTH B		LAND DIAMETER (REFERENCE)		FILLET RADIUS r	BALL COMPLEMENT		LOAD RATINGS LBS	
	mm	INCH	mm	INCH	mm	INCH	Li	Lo		NO.	SIZE	DYN. C	STATIC Co
							INCH	INCH	INCH				
R-1818	90	3.5433	115	4.5276	13	.5118	3.866	4.204	.039	25	9/32	4250	4450
R-1918	90	3.5433	125	4.9213	18	.7087	3.969	4.495	.043	17	7/16	8000	7450
R-118	90	3.5433	140	5.5118	24	.9449	4.151	4.903	.059	13	5/8	13300	11100
R-218	90	3.5433	160	6.2992	30	1.1811	4.394	5.447	.079	10	7/8	21000	15700
R-318	90	3.5433	190	7.4803	43	1.6929	4.797	6.226	.118	8	1-3/16	31400	21800
R-1819	95	3.7402	120	4.7244	13	.5118	4.063	4.401	.039	26	9/32	4350	4650
R-1919	95	3.7402	130	5.1181	18	.7087	4.165	4.692	.043	18	7/16	8400	8100
R-119	95	3.7402	145	5.7087	24	.9449	4.348	5.100	.059	13	5/8	13500	11400
R-219	95	3.7402	170	6.6929	32	1.2598	4.652	5.780	.083	10	15/16	24300	18400
R-319	95	3.7402	200	7.8740	45	1.7717	5.055	6.559	.118	8	1-1/4	35100	24700
R-1820	100	3.9370	125	4.9213	13	.5118	4.259	4.598	.039	27	9/32	4450	4850
R-1920	100	3.9370	140	5.5118	20	.7874	4.423	5.025	.043	17	1/2	10500	9900
R-120	100	3.9370	150	5.9055	24	.9449	4.545	5.297	.059	14	5/8	14100	12400
R-220	100	3.9370	180	7.0866	34	1.3386	4.910	6.113	.083	10	1	27300	20900
R-1821	105	4.1339	130	5.1181	13	.5118	4.456	4.795	.039	28	9/32	4500	5000
R-1921	105	4.1339	145	5.7087	20	.7874	4.620	5.222	.043	17	1/2	10400	9950
R-121	105	4.1339	160	6.2992	26	1.0236	4.802	5.630	.079	13	11/16	16100	13800
R-221	105	4.1339	190	7.4803	36	1.4173	5.167	6.446	.083	10	1-1/16	30500	23500
R-1822	110	4.3307	140	5.5118	16	.6299	4.714	5.128	.039	25	11/32	6200	6800
R-1922	110	4.3307	150	5.9055	20	.7874	4.817	5.418	.043	18	1/2	10700	10600
R-122	110	4.3307	170	6.6929	28	1.1024	5.060	5.963	.079	13	3/4	18900	16300
R-222	110	4.3307	200	7.8740	38	1.4961	5.425	6.779	.079	10	1-1/8	33900	26300
R-1824	120	4.7244	150	5.9055	16	.6299	5.108	5.521	.039	27	11/32	6450	7300
R-1924	120	4.7244	165	6.4961	22	.8661	5.273	5.947	.043	17	9/16	12800	12700
R-124	120	4.7244	180	7.0866	28	1.1024	5.454	6.356	.079	14	3/4	19700	17900
R-224	120	4.7244	215	8.4646	40	1.5748	5.917	7.271	.079	10	1-1/8	33700	26900
R-1826	130	5.1181	165	6.4961	18	.7087	5.563	6.052	.043	25	13/32	8400	9500
R-1926	130	5.1181	180	7.0866	24	.9449	5.726	6.478	.059	17	5/8	15600	15600
R-126	130	5.1181	200	7.8740	33	1.2992	5.971	7.023	.079	13	7/8	25000	22300
R-226	130	5.1181	230	9.0551	40	1.5748	6.372	7.801	.098	10	1-3/16	37200	30100

Notes:

1. Metric series radial ball bearings are typically manufactured from 52100 chrome steel to ABEC 3, 5 and 7 tolerances per ABMA Standard 20.
2. Fillet Radius (r) is the maximum shaft or housing fillet radius that bearing corners will clear.



Metric Series

Radial

Bore Sizes 140-200 mm

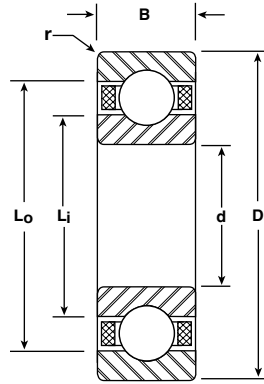

BASIC P/N	BORE d		O.D. D		WIDTH B		LAND DIAMETER (REFERENCE)		FILLET RADIUS r	BALL COMPLEMENT		LOAD RATINGS LBS	
	mm	INCH	mm	INCH	mm	INCH	Li	L0		NO.	SIZE	DYN. C	STATIC Co
							INCH	INCH	INCH		INCH		
R-1828	140	5.5118	175	6.8898	18	.7087	5.956	6.445	.043	26	13/32	8500	9800
R-1928	140	5.5118	190	7.4803	24	.9449	5.923	6.675	.059	18	5/8	16000	16500
R-128	140	5.5118	210	8.2677	33	1.2992	6.363	7.416	.079	14	7/8	26000	24300
R-228	140	5.5118	250	9.8425	42	1.6535	6.887	8.467	.098	10	1-5/16	44600	36600
R-1830	150	5.9055	190	7.4803	20	.7874	6.430	6.956	.043	26	7/16	9700	11400
R-1930	150	5.9055	210	8.2677	28	1.1024	6.635	7.538	.079	16	3/4	20900	21000
R-130	150	5.9055	225	8.8583	35	1.3780	6.855	7.908	.083	15	7/8	26900	36400
R-1832	160	6.2992	200	7.8740	20	.7874	6.823	7.350	.043	28	7/16	10000	12200
R-1932	160	6.2992	220	8.6614	28	1.1024	7.029	7.932	.079	17	3/4	21500	22500
R-132	160	6.2992	240	9.4488	38	1.4961	7.272	8.476	.083	14	1	33100	31800
R-1834	170	6.6929	215	8.4646	22	.8661	7.278	7.880	.043	26	1/2	12400	14900
R-1934	170	6.6929	230	9.0551	28	1.1024	7.423	8.325	.079	18	3/4	22000	24000
R-134	170	6.6929	260	10.2360	42	1.6535	7.788	9.141	.083	13	1-1/8	39200	37000
R-1836	180	7.0866	225	8.8583	22	.8661	7.672	8.273	.043	28	1/2	12800	16000
R-1936	180	7.0866	250	9.8425	33	1.2992	7.938	8.991	.079	17	7/8	28700	30500
R-136	180	7.0866	280	11.0240	46	1.8110	8.378	9.732	.083	14	1-1/8	40800	40400
R-1838	190	7.4803	240	9.4488	24	.9449	8.126	8.803	.059	26	9/16	15400	18900
R-1938	190	7.4803	260	10.2360	33	1.2992	8.332	9.385	.079	17	7/8	28300	30700
R-138	190	7.4803	290	11.4173	46	1.8110	8.734	10.163	.083	14	1-3/16	45500	44400
R-1840	200	7.8740	250	9.8425	24	.9449	8.520	9.197	.059	27	9/16	15600	19500
R-1940	200	7.8740	280	11.0240	38	1.4961	8.847	10.050	.083	16	1	35200	37400

Notes:

1. Metric series radial ball bearings are typically manufactured from 52100 chrome steel to ABEC 3, 5 and 7 tolerances per ABMA Standard 20.
2. Fillet Radius (r) is the maximum shaft or housing fillet radius that bearing corners will clear.

Metric Series

Angular Contact

Bore Sizes 10-25 mm



MER

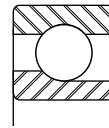
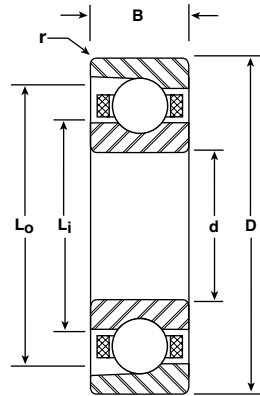

MDR

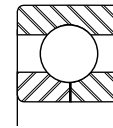

GR split inner

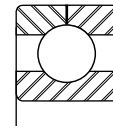

GR split outer

BASIC P/N	BORE d		O.D. D		WIDTH B		LAND DIAMETER (REFERENCE)		FILLET RADIUS r	BALL COMPLEMENT		LOAD RATINGS LBS	
	mm	INCH	mm	INCH	mm	INCH	Li	Lo		NO.	SIZE	DYN. C	STATIC Co
							INCH	INCH	INCH		INCH		
MER-1900	10	.3937	22	.8661	6	.2362	.570	.734	.012	11	1/8	670	340
MER-100	10	.3937	26	1.0236	8	.3150	.583	.837	.012	9	3/16	1200	560
MER-200	10	.3937	30	1.1811	9	.3543	.656	.919	.024	9	7/32	1550	750
MER-300	10	.3937	35	1.3780	11	.4331	.717	1.055	.024	8	9/32	2200	1000
MER-1901	12	.4724	24	.9449	6	.2362	.629	.800	.012	11	9/64	830	430
MER-101	12	.4724	28	1.1024	8	.3150	.670	.924	.012	10	3/16	1300	650
MER-201	12	.4724	32	1.2598	10	.3937	.725	1.007	.024	9	15/64	1800	870
MER-301	12	.4724	37	1.4567	12	.4724	.777	1.153	.039	7	5/16	2400	1100
MER-1902	15	.5906	28	1.1024	7	.2756	.735	.972	.012	12	5/32	1050	590
MER-102	15	.5906	32	1.2598	9	.3543	.816	1.042	.012	11	3/16	1400	760
MER-202	15	.5906	35	1.3780	11	.4331	.815	1.153	.024	10	1/4	2200	1150
MER-302	15	.5906	42	1.6535	13	.5118	.934	1.310	.039	9	5/16	3000	1550
MER-1903	17	.6693	30	1.1811	7	.2756	.832	1.015	.012	13	5/32	1100	660
MER-103	17	.6693	35	1.3780	10	.3937	.895	1.153	.012	13	3/16	1550	930
MER-203	17	.6693	40	1.5748	12	.4724	.952	1.292	.024	10	17/64	2450	1350
MER-303	17	.6693	47	1.8504	14	.5512	1.034	1.485	.039	8	3/8	3750	1900
MER-1804	20	.7874	32	1.2598	7	.2756	.948	1.098	.012	17	1/8	850	580
MER-1904	20	.7874	37	1.4567	9	.3543	1.002	1.267	.012	11	7/32	1850	1050
MER-104	20	.7874	42	1.6535	12	.4724	1.075	1.395	.024	11	1/4	2400	1350
MER-204	20	.7874	47	1.8504	14	.5512	1.131	1.506	.039	10	5/16	3300	1850
MER-304	20	.7874	52	2.0472	15	.5906	1.192	1.643	.039	9	3/8	4200	2250
MER-1805	25	.9843	37	1.4567	7	.2756	1.145	1.295	.012	20	1/8	920	700
MER-1905	25	.9843	42	1.6535	9	.3543	1.195	1.460	.012	14	7/32	2200	1400
MER-105	25	.9843	47	1.8504	12	.4724	1.267	1.567	.024	13	1/4	2650	1700
MER-205	25	.9843	52	2.0472	15	.5906	1.328	1.703	.039	11	5/16	3550	2150
MER-305	25	.9843	62	2.4409	17	.6693	1.450	1.976	.039	9	15/32	5590	3140

Notes:

1. Metric series angular contact ball bearings are typically manufactured from 52100 chrome steel to ABEC 3, 5 and 7 tolerances per ABMA Standard 20.
2. Standard contact angles are 15° and 25°. Other options are available.
3. Part numbers listed are with nonseparable, outer ring relieved configuration. Other design options are available.
4. Fillet Radius (r) is the maximum shaft or housing fillet radius that bearing corners will clear.

**Metric Series
Angular Contact**

Bore Sizes 30-55 mm

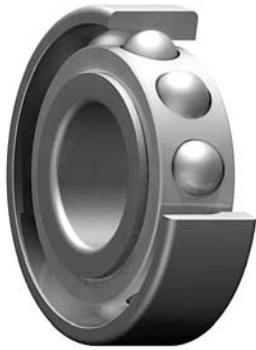

MER

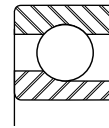
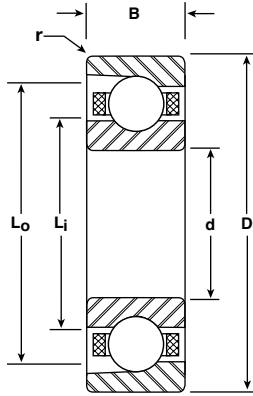

MDR

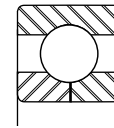

GR
split inner

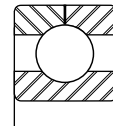

GR
split outer

BASIC P/N	BORE d		O.D. D		WIDTH B		LAND DIAMETER (REFERENCE)		FILLET RADIUS r	BALL COMPLEMENT		LOAD RATINGS LBS	
	mm	INCH	mm	INCH	mm	INCH	Li	Lo		NO.	SIZE	DYN. C	STATIC Co
							INCH	INCH	INCH		INCH		
MER-1806	30	1.1811	42	1.6535	7	.2756	1.342	1.492	.012	23	1/8	970	810
MER-1906	30	1.1811	47	1.8504	9	.3543	1.384	1.649	.012	16	7/32	2350	1650
MER-106	30	1.1811	55	2.1654	13	.5118	1.504	1.842	.039	14	9/32	3450	2350
MER-206	30	1.1811	62	2.4409	16	.6299	1.585	2.045	.039	12	3/8	5250	3350
MER-306	30	1.1811	72	2.8346	19	.7480	1.707	2.308	.039	10	1/2	7700	4650
MER-1807	35	1.3780	47	1.8504	7	.2756	1.539	1.689	.012	26	1/8	1000	900
MER-1907	35	1.3780	55	2.1654	10	.3937	1.644	1.942	.024	18	1/4	3200	2450
MER-107	35	1.3780	62	2.4409	14	.5512	1.721	2.097	.039	15	5/16	4350	3100
MER-207	35	1.3780	72	2.8346	17	.6693	1.825	2.388	.039	10	15/32	6900	4250
MER-307	35	1.3780	80	3.1496	21	.8268	1.926	2.602	.059	10	9/16	9500	5850
MER-1808	40	1.5748	52	2.0472	7	.2756	1.735	1.886	.012	29	1/8	1050	1000
MER-1908	40	1.5748	62	2.4409	12	.4724	1.878	2.141	.024	19	1/4	3250	2700
MER-108	40	1.5748	68	2.6772	15	.5906	1.900	2.351	.039	14	3/8	5800	4100
MER-208	40	1.5748	80	3.1496	18	.7087	2.062	2.663	.039	11	1/2	8300	5450
MER-308	40	1.5748	90	3.5433	23	.9055	2.184	2.935	.059	10	5/8	11500	7300
MER-1809	45	1.7717	58	2.2835	7	.2756	1.952	2.102	.012	31	1/8	1100	1050
MER-1909	45	1.7717	68	2.6772	12	.4724	2.055	2.394	.024	19	9/32	4050	3350
MER-109	45	1.7717	75	2.9528	16	.6299	2.137	2.588	.039	15	3/8	6050	4500
MER-209	45	1.7717	85	3.3465	19	.7480	2.258	2.859	.039	13	15/32	9295	6540
MER-309	45	1.7717	100	3.9370	25	.9843	2.441	3.267	.059	11	11/16	14600	9800
MER-1810	50	1.9685	65	2.5591	7	.2756	2.169	2.357	.012	30	5/32	1585	1560
MER-1910	50	1.9685	72	2.8346	12	.4724	2.232	2.571	.024	21	9/32	4300	3750
MER-110	50	1.9685	80	3.1496	16	.6299	2.334	2.785	.039	18	3/8	6675	5450
MER-210	50	1.9685	90	3.5433	20	.7874	2.455	3.056	.039	14	1/2	9800	7250
MER-310	50	1.9685	110	4.3307	27	1.0630	2.699	3.600	.079	11	3/4	17100	11700
MER-1811	55	2.1654	72	2.8346	9	.3543	2.387	2.612	.012	29	3/16	2300	2300
MER-1911	55	2.1654	80	3.1496	13	.5118	2.469	2.845	.039	20	5/16	5050	4450
MER-111	55	2.1654	90	3.5433	18	.7087	2.592	3.116	.039	17	7/16	8700	7050
MER-211	55	2.1654	100	3.9370	21	.8268	2.713	3.389	.059	14	9/16	12100	9150
MER-311	55	2.1654	120	4.7244	29	1.1417	2.956	3.933	.079	11	13/16	19800	13800

Notes:

- Metric series angular contact ball bearings are typically manufactured from 52100 chrome steel to ABEC 3, 5 and 7 tolerances per ABMA Standard 20.
- Standard contact angles are 15° and 25°. Other options are available.
- Part numbers listed are with nonseparable, outer ring relieved configuration. Other design options are available.
- Fillet Radius (r) is the maximum shaft or housing fillet radius that bearing corners will clear.

Metric Series

Angular Contact

Bore Sizes 60-85 mm

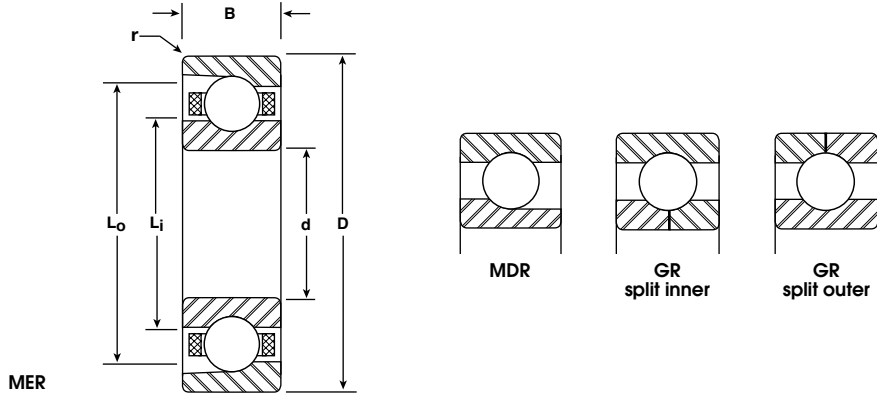
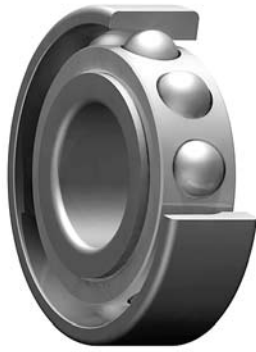

BASIC P/N	BORE d		O.D. D		WIDTH B		LAND DIAMETER (REFERENCE)		FILLET RADIUS r	BALL COMPLEMENT		LOAD RATINGS LBS	
	mm	INCH	mm	INCH	mm	INCH	Li	Lo		NO.	SIZE	DYN. C	STATIC Co
							INCH	INCH	INCH		INCH		
MER-1812	60	2.3622	78	3.0709	10	.3937	2.584	2.848	.012	28	7/32	3050	3050
MER-1912	60	2.3622	85	3.3465	13	.5118	2.666	3.042	.039	21	5/16	5150	4700
MER-112	60	2.3622	95	3.7402	18	.7087	2.788	3.314	.039	18	7/16	8950	7600
MER-212	60	2.3622	110	4.3307	22	.8661	2.971	3.722	.059	14	5/8	14700	11300
MER-312	60	2.3622	130	5.1181	31	1.2205	3.213	4.266	.079	11	7/8	22600	16100
MER-1813	65	2.5591	85	3.3465	10	.3937	2.821	3.084	.024	29	7/32	3050	3150
MER-1913	65	2.5591	90	3.5433	13	.5118	2.863	3.239	.039	23	5/16	5450	5200
MER-113	65	2.5591	100	3.9370	18	.7087	2.985	3.511	.039	19	7/16	9150	8100
MER-213	65	2.5591	120	4.7244	23	.9055	3.228	4.055	.059	14	11/16	17400	13600
MER-313	65	2.5591	140	5.5118	33	1.2992	3.471	4.599	.079	12	15/16	27200	20200
MER-1814	70	2.7559	90	3.5433	10	.3937	3.018	3.281	.024	31	7/32	3150	3350
MER-1914	70	2.7559	100	3.9370	16	.6299	3.139	3.553	.039	21	11/32	6100	5750
MER-114	70	2.7559	110	4.3307	20	.7874	3.243	3.844	.039	18	1/2	11300	9950
MER-214	70	2.7559	125	4.9213	24	.9449	3.424	4.252	.059	15	11/16	18200	14800
MER-314	70	2.7559	150	5.9055	35	1.3780	3.729	4.932	.079	12	1	30500	23000
MER-1815	75	2.9528	95	3.7402	10	.3937	3.214	3.478	.024	33	7/32	3200	3550
MER-1915	75	2.9528	105	4.1339	16	.6299	3.318	3.769	.039	26	3/8	8250	8500
MER-115	75	2.9528	115	4.5276	20	.7874	3.440	4.041	.039	20	1/2	12100	11200
MER-215	75	2.9528	130	5.1181	25	.9843	3.621	4.449	.059	16	11/16	19000	16000
MER-315	75	2.9528	160	6.2992	37	1.4567	3.986	5.265	.079	12	1-1/16	34100	26100
MER-1816	80	3.1496	100	3.9370	10	.3937	3.411	3.675	.024	35	7/32	3300	3750
MER-1916	80	3.1496	110	4.3307	16	.6299	3.515	3.966	.039	27	3/8	8350	8850
MER-116	80	3.1496	125	4.9213	22	.8661	3.809	4.261	.039	19	9/16	14500	13300
MER-216	80	3.1496	140	5.5118	26	1.0236	3.992	4.669	.079	16	3/4	22200	19000
MER-316	80	3.1496	170	6.6929	39	1.5354	4.470	5.372	.079	12	1-1/8	37800	29300
MER-1817	85	3.3465	110	4.3307	13	.5118	3.669	4.007	.039	30	9/32	4900	5450
MER-1917	85	3.3465	120	4.7244	18	.7087	3.772	4.298	.039	25	7/16	10700	11100
MER-117	85	3.3465	130	5.1181	22	.8661	3.893	4.570	.039	20	9/16	14900	14200
MER-217	85	3.3465	150	5.9055	28	1.1024	4.137	5.114	.079	15	13/16	24600	20800
MER-317	85	3.3465	180	7.0866	41	1.6142	4.539	5.893	.098	13	1-1/8	40100	32400

Notes:

1. Metric series angular contact ball bearings are typically manufactured from 52100 chrome steel to ABEC 3, 5 and 7 tolerances per ABMA Standard 20.
2. Standard contact angles are 15° and 25°. Other options are available.
3. Part numbers listed are with nonseparable, outer ring relieved configuration. Other design options are available.
4. Fillet Radius (r) is the maximum shaft or housing fillet radius that bearing corners will clear.



**Metric Series
Angular Contact**

Bore Sizes 90-130 mm

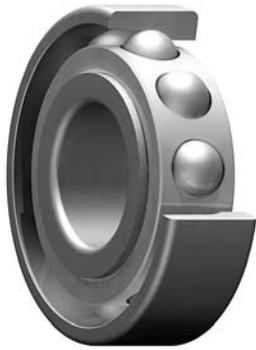

MER

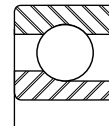
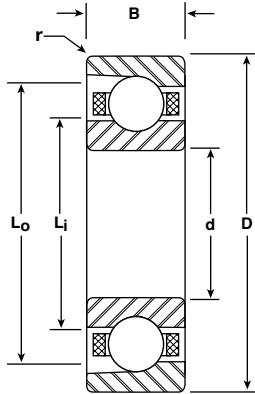

MDR

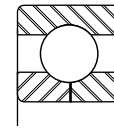

GR split inner

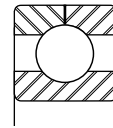

GR split outer

BASIC P/N	BORE d		O.D. D		WIDTH B		LAND DIAMETER (REFERENCE)		FILLET RADIUS r	BALL COMPLEMENT		LOAD RATINGS LBS	
	mm	INCH	mm	INCH	mm	INCH	Li	Lo		NO.	SIZE INCH	DYN. C	STATIC Co
									INCH				
MER-1818	90	3.5433	115	4.5276	13	.5118	3.904	4.166	.039	31	9/32	4950	5600
MER-1918	90	3.5433	125	4.9213	18	.7087	3.969	4.495	.039	26	7/16	10900	11600
MER-118	90	3.5433	140	5.5118	24	.9449	4.151	4.903	.059	20	5/8	18200	17400
MER-218	90	3.5433	160	6.2992	30	1.1811	4.394	5.447	.079	15	7/8	28100	24100
MER-318	90	3.5433	190	7.4803	43	1.6929	4.797	6.226	.098	13	1-3/16	44200	36200
MER-1819	95	3.7402	120	4.7244	13	.5118	4.101	4.363	.039	32	9/32	5000	5750
MER-1919	95	3.7402	130	5.1181	18	.7087	4.169	4.692	.039	28	7/16	11300	12600
MER-119	95	3.7402	145	5.7087	24	.9449	4.348	5.100	.059	21	5/8	18600	18400
MER-219	95	3.7402	170	6.6929	32	1.2598	4.652	5.780	.079	15	15/16	31900	27600
MER-319	95	3.7402	200	7.8740	45	1.7717	5.055	6.559	.098	13	1-1/4	48500	40100
MER-1820	100	3.9370	125	4.9213	13	.5118	4.259	4.598	.039	34	9/32	5150	6100
MER-1920	100	3.9370	140	5.5118	20	.7874	4.423	5.025	.039	26	1/2	13900	15100
MER-120	100	3.9370	150	5.9055	24	.9449	4.545	5.297	.059	21	5/8	18500	18600
MER-220	100	3.9370	180	7.0866	34	1.3386	4.910	6.113	.079	15	1	35800	31300
MER-1821	105	4.1339	130	5.1181	13	.5118	4.456	4.795	.039	36	9/32	5300	6400
MER-1921	105	4.1339	145	5.7087	20	.7874	4.620	5.222	.039	27	1/2	14200	15800
MER-121	105	4.1339	160	6.2992	26	1.0236	4.802	5.630	.079	21	11/16	22100	22300
MER-221	105	4.1339	190	7.4803	36	1.4173	5.167	6.446	.079	15	1-1/16	40000	35300
MER-1822	110	4.3307	140	5.5118	16	.6299	4.714	5.128	.039	32	11/32	7300	8650
MER-1922	110	4.3307	150	5.9055	20	.7874	4.817	5.418	.039	28	1/2	14300	16500
MER-122	110	4.3307	170	6.6929	28	1.1024	5.060	5.963	.079	20	3/4	25200	25100
MER-222	110	4.3307	200	7.8740	38	1.4961	5.425	6.779	.079	15	1-1/8	44300	39400
MER-1824	120	4.7244	150	5.9055	16	.6299	5.108	5.521	.039	35	11/32	7600	9400
MER-1924	120	4.7244	165	6.4961	22	.8661	5.271	5.948	.039	27	9/16	17400	20100
MER-124	120	4.7244	180	7.0866	28	1.1024	5.454	6.356	.079	22	3/4	26600	28000
MER-224	120	4.7244	215	8.4646	40	1.5748	5.917	7.271	.079	16	1-1/8	46200	43000
MER-1826	130	5.1181	165	6.4961	18	.7087	5.562	6.051	.039	32	13/32	9900	12100
MER-1926	130	5.1181	180	7.0866	24	.9449	5.726	6.478	.059	27	5/8	21200	24700
MER-126	130	5.1181	200	7.8740	33	1.2992	5.969	7.022	.079	20	7/8	33200	34300
MER-226	130	5.1181	230	9.0551	40	1.5748	6.372	7.801	.098	17	1-3/16	52900	51200

Notes:

- Metric series angular contact ball bearings are typically manufactured from 52100 chrome steel to ABEC 3, 5 and 7 tolerances per ABMA Standard 20.
- Standard contact angles are 15° and 25°. Other options are available.
- Part numbers listed are with nonseparable, outer ring relieved configuration. Other design options are available.
- Fillet Radius (r) is the maximum shaft or housing fillet radius that bearing corners will clear.

Metric Series

Angular Contact

Bore Sizes 140-200 mm

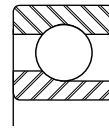
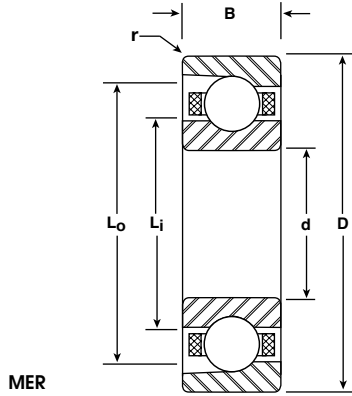
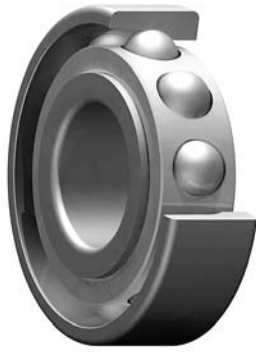

MDR

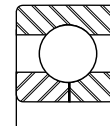

GR split inner

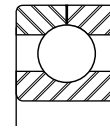

GR split outer

BASIC P/N	BORE d		O.D. D		WIDTH B		LAND DIAMETER (REFERENCE)		FILLET RADIUS r	BALL COMPLEMENT		LOAD RATINGS LBS	
	mm	INCH	mm	INCH	mm	INCH	Li	Lo		NO.	SIZE	DYN. C	STATIC Co
							INCH	INCH	INCH		INCH		
MER-1828	140	5.5118	175	6.8898	18	.7087	5.956	6.445	.039	35	13/32	10300	13200
MER-1928	140	5.5118	190	7.4803	24	.9449	5.923	6.675	.059	29	5/8	22000	26700
MER-128	140	5.5118	210	8.2677	33	1.2992	6.363	7.416	.079	22	7/8	35100	38100
MER-228	140	5.5118	250	9.8425	42	1.6535	6.887	8.466	.098	16	1-5/16	61000	58500
MER-1830	150	5.9055	190	7.4803	20	.7874	6.429	6.956	.039	35	7/16	11800	15300
MER-1930	150	5.9055	210	8.2677	28	1.1024	6.635	7.537	.079	26	3/4	28900	34200
MER-130	150	5.9055	225	8.8583	35	1.3780	6.855	7.908	.079	23	7/8	35800	40400
MER-1832	160	6.2992	200	7.8740	20	.7874	6.823	7.349	.039	37	7/16	12100	16100
MER-1932	160	6.2992	220	8.6614	28	1.1024	7.029	7.931	.079	27	3/4	29300	35800
MER-132	160	6.2992	240	9.4488	38	1.4961	7.272	8.475	.079	22	1	44700	49900
MER-1834	170	6.6929	215	8.4646	22	.8661	7.277	7.879	.039	35	1/2	15100	20000
MER-1934	170	6.6929	230	9.0551	28	1.1024	7.422	8.325	.079	29	3/4	30300	38700
MER-134	170	6.6929	260	10.2360	42	1.6535	7.787	9.141	.079	21	1-1/8	54000	59800
MER-1836	180	7.0866	225	8.8583	22	.8661	7.671	8.273	.039	37	1/2	15500	21100
MER-1936	180	7.0866	250	9.8425	33	1.2992	7.938	8.991	.079	27	7/8	39000	48500
MER-136	180	7.0866	280	11.0240	46	1.8110	8.378	9.732	.079	22	1-1/8	55100	63500
MER-1838	190	7.4803	240	9.4488	24	.9449	8.126	8.803	.059	36	9/16	19100	26200
MER-1938	190	7.4803	260	10.2360	33	1.2992	8.331	9.384	.079	28	7/8	39500	50600
MER-138	190	7.4803	290	11.4173	46	1.8110	8.734	10.163	.079	22	1-3/16	60800	70600
MER-1840	200	7.8740	250	9.8425	24	.9449	8.519	9.196	.059	37	9/16	19200	26800
MER-1940	200	7.8740	280	11.0240	38	1.4961	8.847	10.050	.079	26	1	48600	60800

Notes:

1. Metric series angular contact ball bearings are typically manufactured from 52100 chrome steel to ABEC 3, 5 and 7 tolerances per ABMA Standard 20.
2. Standard contact angles are 15° and 25°. Other options are available.
3. Part numbers listed are with nonseparable, outer ring relieved configuration. Other design options are available.
4. Fillet Radius (r) is the maximum shaft or housing fillet radius that bearing corners will clear.



Inch Series

Radial

Bore Sizes .5000-1.5000 inches

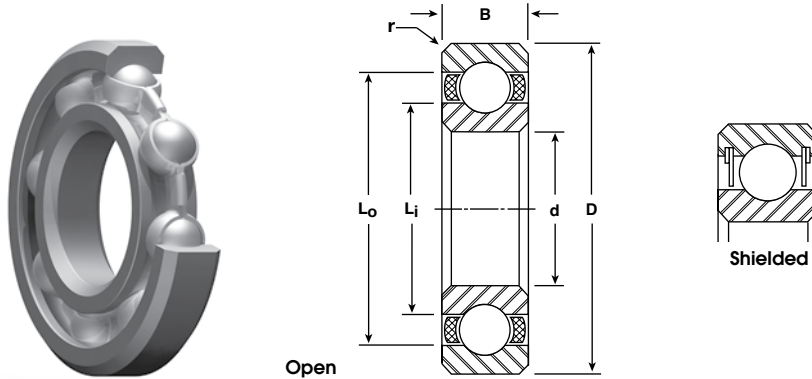

BASIC P/N	BORE d		O.D. D		WIDTH B				LAND DIAMETER (REFERENCE)		FILLET RADIUS r	BALL COMPLEMENT		LOAD RATINGS (LBS)		
					OPEN		SHIELDED		L _i	L _o		NO.	SIZE INCH	RADIAL CAPACITY		THRUST CAPACITY
	INCH	mm	INCH	mm	INCH	mm	INCH	mm	INCH	INCH	INCH			INCH	DYN. C	STATIC C ₀
RI-1812	.5000	12.700	1.1250	28.575	.2500	6.350	.3125	7.938	.701	.913	.016	9	5/32	861	434	290
RI-2258	.6250	15.875	1.3750	34.925	.2812	7.142	.3438	8.732	.852	1.132	.031	8	7/32	1518	747	617
RI-2634	.7500	19.050	1.6250	41.275	.3125	7.938	.4375	11.112	1.020	1.344	.031	8	1/4	1886	951	663
RI-3078	.8750	22.225	1.8750	47.625	.3750	9.525	.5000	12.700	1.266	1.567	.031	10	1/4	2255	1316	960
RI-3216	1.0000	25.400	2.0000	50.800	.3750	9.525	.5000	12.700	1.327	1.703	.031	9	5/16	3145	1763	1396
RI-3418	1.1250	28.575	2.1250	53.975	.3750	9.525	.5000	12.700	1.503	1.842	.031	11	9/32	2966	1857	1467
RI-3620	1.2500	31.750	2.2500	57.150	.3750	9.525	.5000	12.700	1.503	1.842	.031	11	9/32	2966	1857	1414
RI-4224	1.5000	38.100	2.6250	66.675	.4375	11.112	.5625	14.288	1.856	2.269	.031	11	11/32	4258	2786	2238

Notes:

1. Inch series radial ball bearings are typically manufactured from 440C stainless steel.
2. Load ratings shown are for 52100 chrome steel.
3. For part numbers -2258 and -2634, ABEC 3P, 5P and 7P per ABMA Standard 12 apply. For all others, ABEC 3, 5 and 7 per ABMA Standard 20 apply.
4. Fillet Radius (r) is the maximum shaft or housing fillet radius that bearing corners will clear.

Inch Series

Torque Tube – Radial

Bore Sizes .6250-3.0625 inches

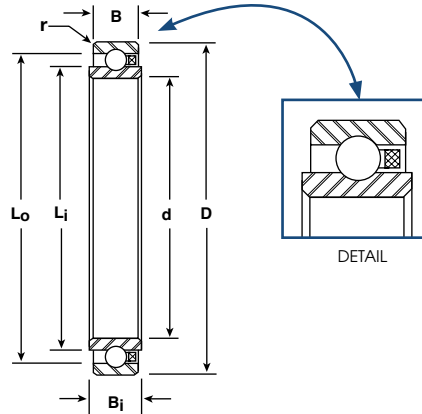

BASIC P/N	BORE d		O.D. D		WIDTH B				LAND DIAMETER (REFERENCE)		FILLET RADIUS r	BALL COMPLEMENT		LOAD RATINGS (LBS)		
	INCH	mm	INCH	mm	INNER B _i		OUTER B		L _i	L _o		NO.	SIZE INCH	RADIAL CAPACITY		THRUST CAPACITY STATIC
					INCH	mm	INCH	mm			DYN. C			STATIC C _o		
RI-538	.6250	15.875	1.0625	26.988	.2812	7.142	.2500	6.350	.773	.933	.015	12	1/8	655	379	271
RI-539	.7500	19.050	1.1875	30.162	.2812	7.142	.2500	6.350	.894	1.054	.015	12	1/8	645	391	272
RI-540	.8750	22.225	1.3125	33.338	.2812	7.142	.2500	6.350	1.019	1.179	.015	14	1/8	705	467	318
RI-541	1.0625	26.988	1.5000	38.100	.2812	7.142	.2500	6.350	1.210	1.368	.015	16	1/8	754	548	365
RI-542	1.3125	33.338	1.7500	44.450	.2812	7.142	.2500	6.350	1.460	1.618	.015	18	1/8	780	632	411
RI-543	1.5625	39.688	2.0000	50.800	.2812	7.142	.2500	6.350	1.706	1.866	.015	25	1/8	935	893	573
RI-544	1.8125	46.038	2.2500	57.150	.2812	7.142	.2500	6.350	1.963	2.123	.015	29	1/8	998	1050	665
RI-545	2.0625	52.388	2.6250	66.675	.2812	7.142	.2500	6.350	2.263	2.423	.015	32	1/8	1028	1172	735
RI-546	2.3125	58.738	2.8750	73.025	.2812	7.142	.2500	6.350	2.513	2.674	.015	34	1/8	1044	1255	794
RI-547	2.5625	65.088	3.2500	82.550	.3750	9.525	.3120	7.925	2.793	3.024	.015	26	3/16	1954	2113	1778
RI-548	2.8125	71.438	3.5000	88.900	.3750	9.525	.3120	7.925	3.043	3.275	.015	28	3/16	2011	2293	1818
RI-549	3.0625	77.788	3.8750	98.425	.3750	9.525	.3120	7.925	3.352	3.589	.015	32	3/16	2147	2652	2031

Notes:

1. Torque tube radial ball bearings are typically manufactured from 440C stainless steel.
2. Load ratings shown are for 52100 chrome steel.
3. The standard retainer design is a phenolic crown. Please check with NHBB for availability of other retainer options.
4. Standard tolerances are ABEC 5T per ABMA Standard 12. ABEC 7T tolerances are also available.
5. Fillet Radius (r) is the maximum shaft or housing fillet radius that bearing corners will clear.



Inch Series

Torque Tube - Angular Contact

Bore Sizes .6250-3.0625 inches

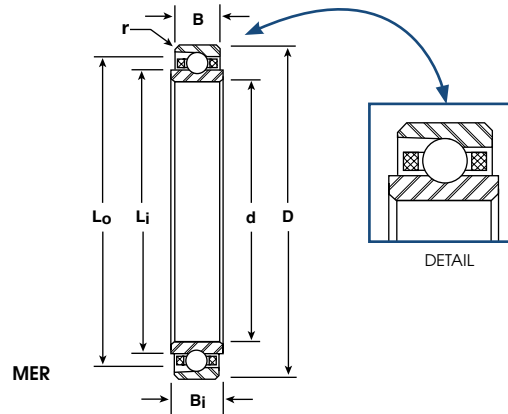

BASIC P/N	BORE d		O.D. D		WIDTH B				LAND DIAMETER (REFERENCE)		FILLET RADIUS r	BALL COMPLEMENT		LOAD RATINGS (LBS)		
	INCH	mm	INCH	mm	INNER Bi		OUTER B		Li	Lo		NO.	SIZE INCH	RADIAL CAPACITY		THRUST CAPACITY STATIC
					DYN. C	STATIC Co										
MERI-538	.6250	15.875	1.0625	26.988	.2812	7.142	.2500	6.350	.773	.933	.015	16	1/8	793	506	362
MERI-539	.7500	19.050	1.1875	30.162	.2812	7.142	.2500	6.350	.894	1.054	.015	18	1/8	845	587	408
MERI-540	.8750	22.225	1.3125	33.338	.2812	7.142	.2500	6.350	1.019	1.179	.015	20	1/8	894	668	455
MERI-541	1.0625	26.988	1.5000	38.100	.2812	7.142	.2500	6.350	1.210	1.370	.015	24	1/8	988	822	549
MERI-542	1.3125	33.338	1.7500	44.450	.2812	7.142	.2500	6.350	1.460	1.620	.015	28	1/8	1047	983	640
MERI-543	1.5625	39.688	2.0000	50.800	.2812	7.142	.2500	6.350	1.706	1.866	.015	34	1/8	1147	1215	779
MERI-544	1.8125	46.038	2.2500	57.150	.2812	7.142	.2500	6.350	1.960	2.120	.015	38	1/8	1196	1375	872
MERI-545	2.0625	52.388	2.6250	66.675	.2812	7.142	.2500	6.350	2.263	2.423	.015	44	1/8	1272	1612	1011
MERI-546	2.3125	58.738	2.8750	73.025	.2812	7.142	.2500	6.350	2.513	2.674	.015	48	1/8	1314	1772	1117
MERI-547	2.5625	65.088	3.2500	82.550	.3750	9.525	.3120	7.925	2.793	3.019	.015	36	3/16	2428	2926	2462
MERI-548	2.8125	71.438	3.5000	88.900	.3750	9.525	.3120	7.925	3.043	3.269	.015	39	3/16	2508	3194	2533
MERI-549	3.0625	77.788	3.8750	98.425	.3750	9.525	.3120	7.925	3.356	3.582	.015	42	3/16	2573	3467	2666

Notes:

1. Torque tube angular contact ball bearings are typically manufactured from 440C stainless steel.
2. Load ratings shown are for 52100 chrome steel.
3. Part numbers listed are with outer ring relieved configuration. Other design options are available.
4. The standard retainer is a one-piece phenolic. Please check with NHBB for availability of other retainer options.
5. Standard tolerances are ABEC 5T per ABMA Standard 12. ABEC 7T tolerances are also available.
6. Fillet Radius (r) is the maximum shaft or housing fillet radius that bearing corners will clear.



Inch Series

Thin Section – Radial and Gothic Arch

Bore Sizes .8750-4.2500 inches

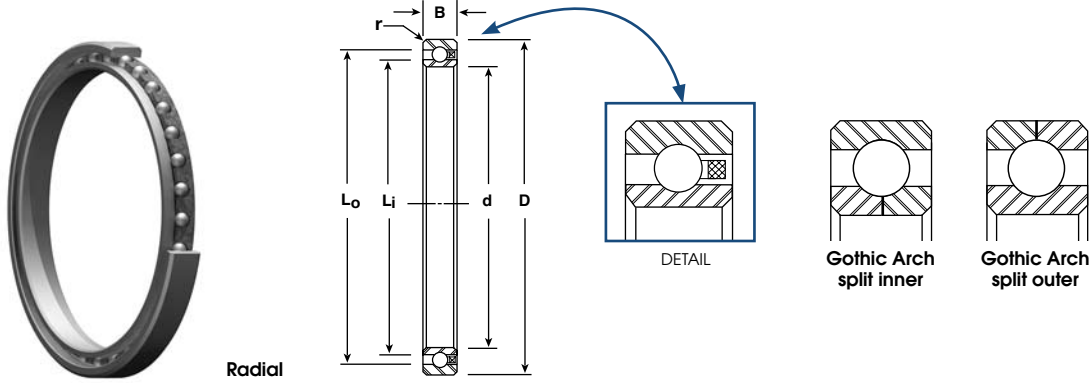

REF.	BASIC P/N	BORE d INCH	O.D. D INCH	WIDTH B INCH	LAND DIAMETER (REFERENCE)		FILLET RADIUS r INCH	BALL COMPLEMENT		LOAD RATINGS (LBS)		
					Li INCH	Lo INCH		NO.	SIZE INCH	RADIAL CAPACITY		THRUST CAPACITY
					DYN. C	STATIC Co				STATIC		
1/8	RI-1878	.8750	1.1250	.1562 ●	.961	1.049	.010	24	1/16	171	134	226
1/8	RI-2117	1.0625	1.3125	.1562 ●	1.144	1.231	.010	28	1/16	182	159	267
1/8	RI-2420	1.2500	1.5000	.1562 ●	1.320	1.402	.010	32	1/16	192	184	309
1/8	RI-2622	1.3750	1.6250	.1562 ●	1.457	1.543	.010	36	1/16	203	208	350
1/8	RI-2824	1.5000	1.7500	.1562 ●	1.584	1.666	.010	38	1/16	206	211	371
1/8	RI-3026	1.6250	1.8750	.1562 ●	1.709	1.793	.010	42	1/16	216	245	412
1/4	RI-4032	2.0000	2.5000	.2500	2.325	2.174	.025	30	1/8	995	1096	951
5/16	RI-4232	2.0000	2.6250	.3125	2.375	2.406	.040	25	5/32	1132	1096	2413
1/4	RI-4840	2.5000	3.0000	.2500	2.674	2.825	.025	36	1/8	1069	1334	1074
5/16	RI-5040	2.5000	3.1250	.3125	2.731	2.893	.040	30	5/32	1125	1216	2335
1/4	RI-5648	3.0000	3.5000	.2500	3.174	3.326	.025	43	1/8	1153	1610	1237
5/16	RI-5848	3.0000	3.6250	.3125	3.234	3.391	.040	33	5/32	1245	1492	3284
3/8	RI-6048	3.0000	3.7500	.3750	3.281	3.469	.040	30	3/16	1688	1917	4098
1/4	RI-6052	3.2500	3.7500	.2500	3.437	3.567	.025	45	1/8	898	1228	2514
5/16	RI-6252	3.2500	3.8750	.3125	3.484	3.641	.040	36	5/32	1197	1485	2853
3/8	RI-6452	3.2500	4.0000	.3750	3.535	3.723	.040	32	3/16	1616	1899	3577
1/4	RI-6456	3.5000	4.0000	.2500	3.688	3.811	.025	49	1/8	934	1342	2747
5/16	RI-6656	3.5000	4.1250	.3125	3.730	3.894	.040	40	5/32	1262	1657	3273
3/8	RI-6856	3.5000	4.2500	.3750	3.718	3.907	.040	33	3/16	1622	1968	3799
1/4	RI-6860	3.7500	4.2500	.2500	3.937	4.063	.025	52	1/8	956	1429	2924
5/16	RI-7060	3.7500	4.3750	.3125	3.984	4.141	.040	42	5/32	1284	1747	3449
3/8	RI-7260	3.7500	4.5000	.3750	4.031	4.219	.040	35	3/16	1660	2096	4048
1/4	RI-7264	4.0000	4.5000	.2500	4.187	4.313	.025	55	1/8	723	964	3200
5/16	RI-7464	4.0000	4.6250	.3125	4.234	4.391	.040	45	5/32	1324	1877	3708
3/8	RI-7664	4.0000	4.7500	.3750	4.281	4.469	.040	36	3/16	1667	2164	4227
1/2	RI-8064	4.0000	5.0000	.5000	4.375	4.625	.060	28	1/4	2514	2920	5455
1/4	RI-7668	4.2500	4.7500	.2500	4.437	4.563	.025	57	1/8	987	1574	3324
5/16	RI-7868	4.2500	4.8750	.3125	4.484	4.641	.040	46	5/32	1325	1925	3801
3/8	RI-8068	4.2500	5.0000	.3750	4.531	4.719	.040	38	3/16	1936	2775	4477
1/2	RI-8468	4.2500	5.2500	.5000	4.625	4.875	.060	30	1/4	2597	3142	5983

- Notes:**
- Inch series thin section ball bearings are typically manufactured from 440C stainless steel.
 - Load ratings shown are for 52100 chrome steel.
 - NHBB typically manufactures thin section bearings to ABEC 5T and 7T tolerances per AMBA Standard 12 (bore diameters up to 1.6250 inches) and ABEC 5F and 7F tolerances per ABMA standard 26 (bore diameters above 1.6250 inches).
 - For gothic arch configuration, add a "G" prefix.
 - Fillet Radius (r) is the maximum shaft or housing fillet radius that bearing corners will clear.
 - Gothic arch bearings (4-point ball-to-race contact) provide for reduced internal free play in axial and radial directions.
 - Radial bearings accept moderate radial and thrust loads at lower speeds.
- Open width shown; shielded width is .1960 inches.



Inch Series

Thin Section – Radial and Gothic Arch

Bore Sizes 4.5000-10.0000 inches

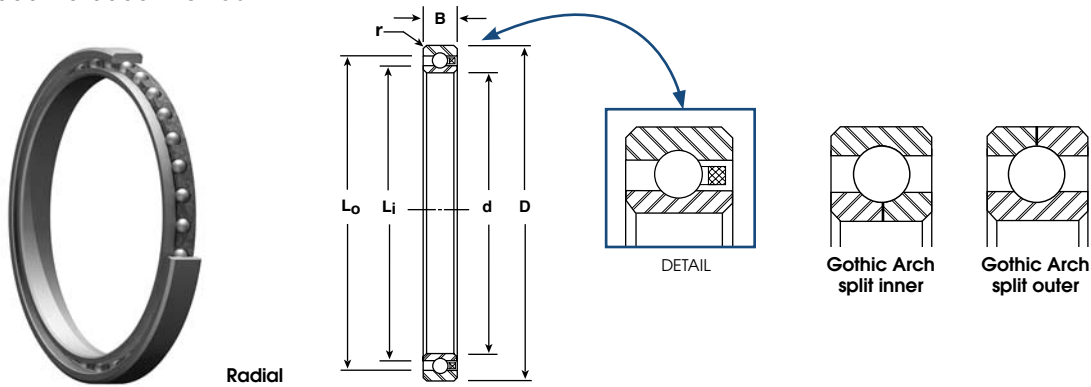

REF.	BASIC P/N	BORE d INCH	O.D. D INCH	WIDTH B INCH	LAND DIAMETER (REFERENCE)		FILLET RADIUS r INCH	BALL COMPLEMENT		LOAD RATINGS (LBS)		
					Li INCH	L0 INCH		NO.	SIZE INCH	RADIAL CAPACITY		THRUST CAPACITY
					DYN. C	STATIC C0				STATIC		
1/4	RI-8072	4.5000	5.0000	.2500	4.687	4.813	.025	60	1/8	1008	1660	3506
5/16	RI-8272	4.5000	5.1250	.3125	4.734	4.891	.040	48	5/32	1345	2014	4080
3/8	RI-8472	4.5000	5.2500	.3750	4.781	4.969	.040	40	3/16	1740	2421	4836
1/2	RI-8872	4.5000	5.5000	.5000	4.875	5.125	.060	32	1/4	2676	3365	6408
1/4	RI-8476	4.7500	5.2500	.2500	4.937	5.063	.025	64	1/8	1035	1774	3857
5/16	RI-8676	4.7500	5.3750	.3125	4.984	5.141	.040	51	5/32	1382	2145	4346
3/8	RI-8876	4.7500	5.5000	.3750	5.031	5.219	.040	43	3/16	1797	2597	5213
1/2	RI-9276	4.7500	5.7500	.5000	5.125	5.375	.060	33	1/4	2702	3489	6632
1/4	RI-8880	5.0000	5.5000	.2500	5.197	5.319	.025	66	1/8	1047	1833	3870
5/16	RI-9080	5.0000	5.6250	.3125	5.234	5.391	.040	55	5/32	1436	2318	4696
3/8	RI-9280	5.0000	5.7500	.3750	5.281	5.469	.040	46	3/16	1864	2798	5591
1/2	RI-9680	5.0000	6.0000	.5000	5.375	5.625	.060	35	1/4	2774	3705	7058
5/16	RI-9888	5.5000	6.1250	.3125	5.734	5.891	.040	58	5/32	1459	2462	4971
3/8	RI-10088	5.5000	6.2500	.3750	5.781	5.969	.040	49	3/16	1901	2994	5982
1/2	RI-10488	5.5000	6.5000	.5000	5.875	6.125	.060	37	1/4	2816	3939	7505
5/16	RI-10696	6.0000	6.6250	.3125	6.234	6.391	.040	63	5/32	1510	2682	5416
3/8	RI-10896	6.0000	6.7500	.3750	6.281	6.469	.040	53	3/16	1962	3250	6494
1/2	RI-11296	6.0000	7.0000	.5000	6.375	6.625	.060	41	1/4	2955	7386	8357
5/16	RI-114104	6.5000	7.1250	.3125	6.734	6.891	.040	68	5/32	1559	2903	5891
3/8	RI-116104	6.5000	7.2500	.3750	6.781	6.969	.040	55	3/16	1973	3383	6760
1/2	RI-120104	6.5000	7.5000	.5000	6.875	7.125	.060	44	1/4	3041	4725	9006
3/8	RI-124112	7.0000	7.7500	.3750	7.281	7.469	.040	59	3/16	2032	3639	7272
1/2	RI-128112	7.0000	8.0000	.5000	7.375	7.625	.060	47	1/4	3123	5065	9655
3/8	RI-132120	7.5000	8.2500	.3750	7.781	7.969	.040	63	3/16	2105	3890	7783
1/2	RI-136120	7.5000	8.5000	.5000	7.875	8.125	.060	50	1/4	3202	5405	10303
3/8	RI-140128	8.0000	8.7500	.3750	8.281	8.469	.040	67	3/16	2147	4151	8295
1/2	RI-144128	8.0000	9.0000	.5000	8.375	8.625	.060	53	1/4	3278	5745	10952
1/2	RI-152136	8.5000	9.5000	.5000	8.875	9.125	.060	56	1/4	3352	6084	11600
1/2	RI-160144	9.0000	10.0000	.5000	9.375	9.469	.060	60	1/4	3463	6533	12456
1/2	RI-168152	9.5000	10.5000	.5000	9.875	10.125	.060	63	1/4	3531	6873	13105
1/2	RI-176160	10.0000	11.0000	.5000	10.375	10.625	.060	66	1/4	3598	7212	13754

Notes:

1. Inch series thin section ball bearings are typically manufactured from 440C stainless steel.
2. Load ratings shown are for 52100 chrome steel.
3. NHBB typically manufactures thin section bearings to ABEC 5T and 7T tolerances per AMBA Standard 12 (bore diameters up to 1.6250 inches) and ABEC 5F and 7F tolerances per ABMA standard 26 (bore diameters above 1.6250 inches).
4. For gothic arch configuration, add a "G" prefix.
5. Fillet Radius (r) is the maximum shaft or housing fillet radius that bearing corners will clear.
6. Gothic arch bearings (4-point ball-to-race contact) provide for reduced internal free play in axial and radial directions.
7. Radial bearings accept moderate radial and thrust loads at lower speeds.

Inch Series
Thin Section - Angular Contact

Bore Sizes .8750-4.2500

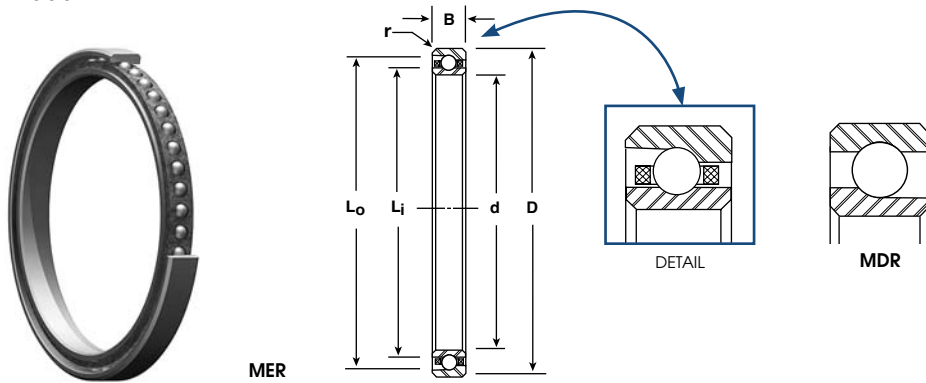

REF.	BASIC P/N	BORE d	O.D. D	WIDTH B	LAND DIAMETER (REFERENCE)		FILLET RADIUS r	BALL COMPLEMENT		LOAD RATINGS (LBS)		
					Li	Lo		NO.	SIZE INCH	RADIAL CAPACITY		THRUST CAPACITY
					INCH	INCH				DYN. C	STATIC Co	STATIC
1/8	MERI-1878	.8750	1.1250	.1562	.961	1.049	.010	32	1/16	208	179	325
1/8	MERI-2117	1.0625	1.3125	.1562	1.144	1.231	.010	38	1/16	223	216	363
1/8	MERI-2420	1.2500	1.5000	.1562	1.320	1.402	.010	44	1/16	237	253	425
1/8	MERI-2622	1.3750	1.6250	.1562	1.457	1.543	.010	49	1/16	249	283	476
1/8	MERI-2824	1.5000	1.7500	.1562	1.584	1.666	.010	53	1/16	257	308	517
1/8	MERI-3026	1.6250	1.8750	.1562	1.709	1.793	.010	57	1/16	265	332	557
1/4	MERI-4032	2.0000	2.5000	.2500	2.325	2.174	.025	36	1/8	1124	1315	1141
5/16	MERI-4232	2.0000	2.6250	.3125	2.375	2.406	.040	31	5/32	1307	1359	2992
1/4	MERI-4840	2.5000	3.0000	.2500	2.674	2.825	.025	44	1/8	1222	1631	1313
5/16	MERI-5040	2.5000	3.1250	.3125	2.731	2.893	.040	38	5/32	1425	1696	3735
1/4	MERI-5648	3.0000	3.5000	.2500	3.174	3.326	.025	52	1/8	1309	1947	1496
5/16	MERI-5848	3.0000	3.6250	.3125	3.234	3.391	.040	44	5/32	1394	1806	3470
3/8	MERI-6048	3.0000	3.7500	.3750	3.281	3.469	.040	37	3/16	1812	2183	4158
1/4	MERI-6052	3.2500	3.7500	.2500	3.437	3.567	.025	56	1/8	1039	1529	3128
5/16	MERI-6252	3.2500	3.8750	.3125	3.484	3.641	.040	47	5/32	1450	1980	3725
3/8	MERI-6452	3.2500	4.0000	.3750	3.535	3.723	.040	40	3/16	1875	2374	4522
1/4	MERI-6456	3.5000	4.0000	.2500	3.688	3.811	.025	60	1/8	1069	1644	3364
5/16	MERI-6656	3.5000	4.1250	.3125	3.730	3.894	.040	51	5/32	1484	2113	4173
3/8	MERI-6856	3.5000	4.2500	.3750	3.718	3.907	.040	43	3/16	1935	2564	5006
1/4	MERI-6860	3.7500	4.2500	.2500	3.937	4.063	.025	64	1/8	1098	1758	3713
5/16	MERI-7060	3.7500	4.3750	.3125	3.984	4.141	.040	54	5/32	1518	2246	4435
3/8	MERI-7260	3.7500	4.5000	.3750	4.031	4.219	.040	46	3/16	1992	2755	5380
1/4	MERI-7264	4.0000	4.5000	.2500	4.187	4.313	.025	68	1/8	1126	1873	3956
5/16	MERI-7464	4.0000	4.6250	.3125	4.234	4.391	.040	58	5/32	1568	2420	4779
3/8	MERI-7664	4.0000	4.7500	.3750	4.281	4.469	.040	49	3/16	2047	2946	5753
1/2	MERI-8064	4.0000	5.0000	.5000	4.375	4.625	.060	36	1/4	2973	3754	7014
1/4	MERI-7668	4.2500	4.7500	.2500	4.437	4.563	.025	72	1/8	1153	1988	4198
5/16	MERI-7868	4.2500	4.8750	.3125	4.484	4.641	.040	61	5/32	1599	2552	5041
3/8	MERI-8068	4.2500	5.0000	.3750	4.531	4.719	.040	52	3/16	2110	3137	6127
1/2	MERI-8468	4.2500	5.2500	.5000	4.625	4.875	.060	38	1/4	3040	3980	7579

Notes:

- Angular contact thin section ball bearings are typically manufactured from 440C stainless steel.
 - Load ratings shown are for 52100 chrome steel.
 - NHBB typically manufactures thin section bearings to ABEC 5T and 7T tolerances per AMBA Standard 12 (bore diameters up to 1.6250 inches) and ABEC 5F and 7F tolerances per ABMA standard 26 (bore diameters above 1.6250 inches).
 - Part numbers listed are with outer ring relieved configuration. Other design options are available.
 - Fillet Radius (r) is the maximum shaft or housing fillet radius that bearing corners will clear.
- Open width shown; shielded width is .1960 inches.



Inch Series

Thin Section – Angular Contact

Bore Sizes 4.5000-10.0000 inches



MER

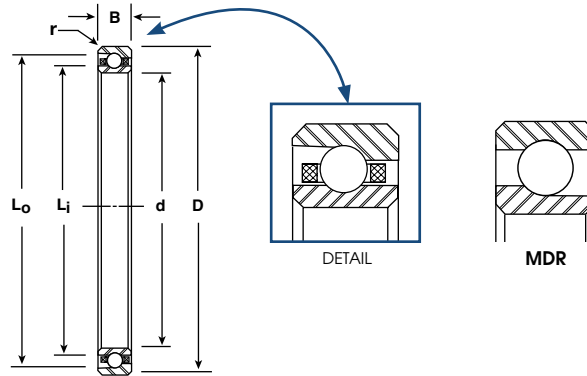

REF.	BASIC P/N	BORE d INCH	O.D. D INCH	WIDTH B INCH	LAND DIAMETER (REFERENCE)		FILLET RADIUS r INCH	BALL COMPLEMENT		LOAD RATINGS (LBS)		
					Li INCH	L0 INCH		NO.	SIZE INCH	RADIAL CAPACITY		THRUST CAPACITY
					DYN. C	STATIC C0				STATIC		
1/4	MERI-8072	4.5000	5.0000	.2500	4.687	4.813	.025	75	1/8	1169	2075	4382
5/16	MERI-8272	4.5000	5.1250	.3125	4.734	4.891	.040	64	5/32	1629	2685	5186
3/8	MERI-8472	4.5000	5.2500	.3750	4.781	4.969	.040	55	3/16	2152	3328	7738
1/2	MERI-8872	4.5000	5.5000	.5000	4.875	5.125	.060	40	1/4	3106	4206	8010
1/4	MERI-8476	4.7500	5.2500	.2500	4.937	5.063	.025	80	1/8	1205	2218	4822
5/16	MERI-8676	4.7500	5.3750	.3125	4.984	5.141	.040	68	5/32	1674	2859	5453
3/8	MERI-8876	4.7500	5.5000	.3750	5.031	5.219	.040	58	3/16	2193	3503	7032
1/2	MERI-9276	4.7500	5.7500	.5000	5.125	5.375	.060	42	1/4	3169	4432	8441
1/4	MERI-8880	5.0000	5.5000	.2500	5.197	5.319	.025	84	1/8	1230	2333	5071
5/16	MERI-9080	5.0000	5.6250	.3125	5.234	5.391	.040	71	5/32	1703	2992	6063
3/8	MERI-9280	5.0000	5.7500	.3750	5.281	5.469	.040	61	3/16	2250	3711	7415
1/2	MERI-9680	5.0000	6.0000	.5000	5.375	5.625	.060	44	1/4	3231	4658	8873
5/16	MERI-9888	5.5000	6.1250	.3125	5.734	5.891	.040	78	5/32	1777	3311	6658
3/8	MERI-10088	5.5000	6.2500	.3750	5.781	5.969	.040	66	3/16	2318	4032	8058
1/2	MERI-10488	5.5000	6.5000	.5000	5.875	6.125	.060	48	1/4	3350	5110	9736
5/16	MERI-10696	6.0000	6.6250	.3125	6.234	6.391	.040	85	5/32	1844	3619	7307
3/8	MERI-10896	6.0000	6.7500	.3750	6.281	6.469	.040	72	3/16	2407	4415	8222
1/2	MERI-11296	6.0000	7.0000	.5000	6.375	6.625	.060	52	1/4	3463	5562	10599
5/16	MERI-114104	6.5000	7.1250	.3125	6.734	6.891	.040	91	5/32	1893	3885	7843
3/8	MERI-116104	6.5000	7.2500	.3750	6.781	6.969	.040	78	3/16	2491	4798	9588
1/2	MERI-120104	6.5000	7.5000	.5000	6.875	7.125	.060	56	1/4	3571	6014	11462
3/8	MERI-124112	7.0000	7.7500	.3750	7.281	7.469	.040	83	3/16	2551	5119	10230
1/2	MERI-128112	7.0000	8.0000	.5000	7.375	7.625	.060	60	1/4	3675	6466	12325
3/8	MERI-132120	7.5000	8.2500	.3750	7.781	7.969	.040	89	3/16	2650	5496	10996
1/2	MERI-136120	7.5000	8.5000	.5000	7.875	8.125	.060	64	1/4	3775	6918	13188
3/8	MERI-140128	8.0000	8.7500	.3750	8.281	8.469	.040	95	3/16	2703	5885	11761
1/2	MERI-144128	8.0000	9.0000	.5000	8.375	8.625	.060	68	1/4	3871	7371	14052
1/2	MERI-152136	8.5000	9.5000	.5000	8.875	9.125	.060	72	1/4	3964	7823	14915
1/2	MERI-160144	9.0000	10.0000	.5000	9.375	9.469	.060	76	1/4	4054	8275	15778
1/2	MERI-168152	9.5000	10.5000	.5000	9.875	10.125	.060	80	1/4	4141	8727	16641
1/2	MERI-176160	10.0000	11.0000	.5000	10.375	10.625	.060	84	1/4	4226	9179	17505

Notes:

- Angular contact thin section ball bearings are typically manufactured from 440C stainless steel.
- Load ratings shown are for 52100 chrome steel.
- NHBB typically manufactures thin section bearings to ABEC 5T and 7T tolerances per ABMA Standard 12 (bore diameters up to 1.6250 inches) and ABEC 5F and 7F tolerances per ABMA standard 26 (bore diameters above 1.6250 inches).
- Part numbers listed are with outer ring relieved configuration. Other design options are available.
- Fillet Radius (r) is the maximum shaft or housing fillet radius that bearing corners will clear.

ADIFOR AERO

Complex Bearing Assemblies with Customized Features



NHBB manufactures a wide range of special bearings designed to meet specific requirements. If the challenge you face involves high load, extreme speed, limited space, simplified assembly, efficient distribution of lubrication, or any number of similar situations requiring custom design, we're ready to help.

A sampling of our special design features include anti-rotation tabs to prevent ring rotation under load, oil scavenge holes to enable lubricant circulation and removal, and puller grooves to allow for simple disassembly. Read on to see what our experienced staff of applications engineers can design specifically for you.

Mainshaft Bearing Assemblies with Integral Flexure Beams

These complex bearing assemblies incorporate flexure beams to control vibration at high speeds.



Cylindrical Roller Bearing Gas Turbine Mainshaft

This unique bearing features an innovative extended inner ring to direct the flow and enhance the distribution of spent lubricant during the scavenge process.



Complex Bearing Assemblies with Customized Features

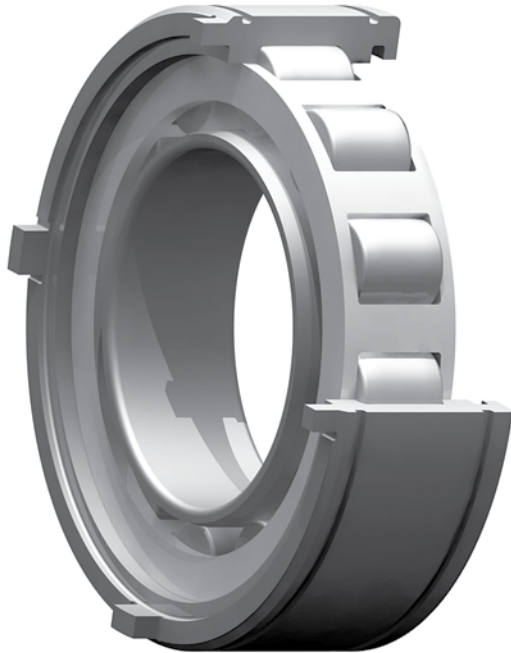

**Cylindrical Roller Bearing
Gas Turbine Mainshaft**

A series of integral anti-rotation tabs prevent the ring on this bearing from rotating under load. The piston ring grooves machined into the outer ring accommodate fluid-damped mounting to further reduce vibration.

**Super Duplex Ball Bearing
Main Fuel Pump**

A locator flange on the outer ring ensures precise positioning and ease of installation. This bearing is supplied as a matched set for high moment resistance.

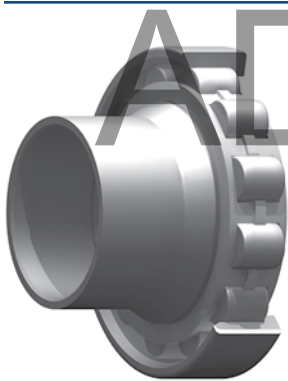

**Cylindrical Roller Bearing
Aircraft Engine
Hydraulic Pump**

This unique design features an extended inner ring to allow offset mounting under tight space constraints.



**Cylindrical Roller Bearing
Gas Turbine Engine
Accessory Gearbox**

The integral flange of this bearing simplifies mounting while the oil holes on the inner ring ensure consistent lubrication.



**Radial Ball Bearing
Gas Turbine Engine
Accessory Gearbox**

The integral flange and puller groove allow for ease of installation and simple disassembly.

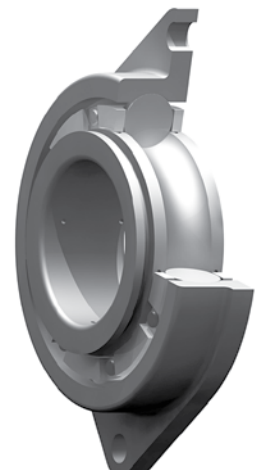

Complex Bearing Assemblies with Customized Features

**Super Duplex Ball Bearing
Gas Turbine Power Take Off**

The puller groove on this bearing simplifies disassembly while the oil scavenge holes enable spent lubricant to exit freely.



**Matched Set of Six Ball Bearings
Helicopter Blade Retention**

These bearings are designed to accommodate extremely high thrust loads and can be ordered in matched sets of two to eight.

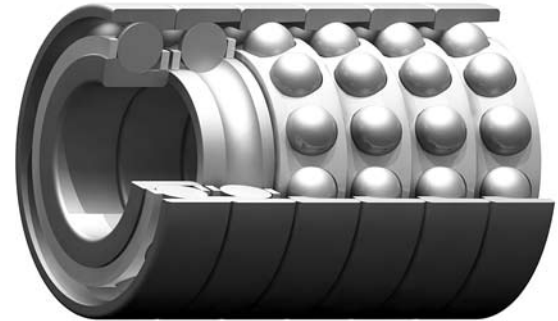

**Duplex Ball Bearing
Main Fuel Pump**

The integral mounting flange and full sleeve on this bearing provide ease of installation and fit.



Gothic Arch Ball Bearing

The split inner ring of this bearing minimizes end play which reduces wear and extends the useful life of the application. The puller groove simplifies disassembly.

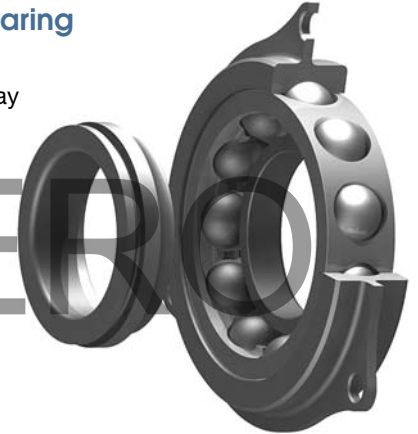

**Full Complement
Thin Section
Ball Bearing
Helicopter Rotor
Swash Plate**

Specified when bearing weight and size need to be kept to a minimum, this bearing has a thin cross section and a high quantity of small diameter balls which increase stiffness, reduce deflection, and lower starting and running torque.

**Duplex Tandem Ball Bearing
Helicopter Main Gearbox**

This bearing was designed specifically for high thrust capacity. A split inner ring minimizes end play, thereby reducing wear and extending the useful life of the gearbox.

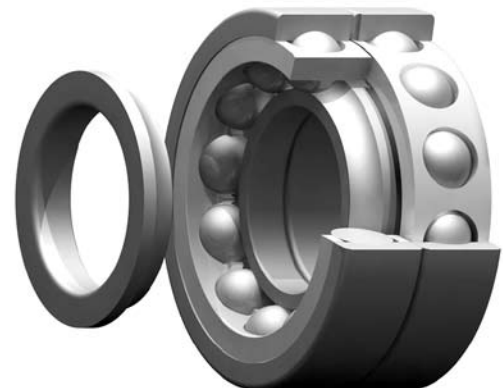

ADIFOR AERO

Materials

The most common materials used in rolling element bearings include 52100 chrome steel, 440C stainless steel and M50 tool steel. While these standard materials are suitable for most applications, extraordinary operating conditions often require the use of more advanced alloys such as BG42®, M50 NiL and Cobalt-based alloys, which offer superb performance at high speeds, extreme temperatures, heavy loads and in corrosive conditions. Although cost considerations occasionally override longevity, the expense involved in more frequent bearing

replacement often justifies the higher initial costs of specifying longer-lasting specialty metals.

A detailed analysis of the factors involved in a specific application is required before selecting the correct material. The following table, while not a complete list of available alloys, is a helpful starting point to the selection process. Please contact NHBB's Applications Engineering department for help with making a final determination.

Ring Material Properties

MATERIAL	SPECIFICATION	MELT METHOD	FEATURES AND ADVANTAGES	HARDNESS AT ROOM TEMP. (HRC)	OPERATING TEMP. LIMIT	HEAT TREATMENT ATTRIBUTES
52100	AMS 6440	Vacuum degassed	Available in tube form	60-64	310 °F	Good wear and fatigue properties
	AMS 6444	CEVM●	Premium quality Very low impurity level	58-62	400 °F	Improved thermal stability
				60-64	310 °F	Good wear and fatigue properties
				58-62	400 °F	Improved thermal stability
440C	AMS 5880	Air melt or vacuum degassed	Corrosion resistance	58-62	325 °F	Good wear properties
				56-60	825 °F	Thermal stability with corrosion resistance
	AMS 5618	CEVM●	Premium quality Low impurity level	58-62	325 °F	Good wear properties
				56-60	825 °F	Thermal stability with corrosion resistance
M50	AMS 6491	VIM/VAR■	Premium quality High temperature capabilities	60-64	975 °F	Excellent fatigue properties High thermal stability
BG42®	AMS 5749	VIM/VAR■	Premium quality Corrosion resistance High temperature capabilities	61-65	950 °F	Excellent wear properties High thermal stability
Nitrogen enriched steel	AMS 5898	P-ESR◆	Extreme corrosion resistance	60-64	850 °F	Improved toughness Improved compressive strength
Cobalt-based alloys	AMS 5759	CEVM●	Chemical resistance High temperature capabilities	50 (min.)	1000 °F	Good thermal stability Low hardness reduction at elevated temperatures
M50 NiL	AMS 6278	VIM/VAR■	Carburized High temperature capabilities High cost	Case: 60 (min.)	975 °F	High fracture toughness of core Accommodates high hoop stresses and cyclic loading

HiTech purchases all products per AMS industry standards and/or NHBB product engineering standards.

- Consumable Electrode Vacuum Melted.
- Vacuum Induction Melted/Vacuum Arc Remelted.
- ◆ Pressure Electroslag Remelting.

BG42® is a registered trademark of Latrobe Specialty Steel Company.

Materials

Fatigue Life

Bearing steels possess specific characteristics that play a critical role in bearing performance. Choosing a material with the correct values for hardness, corrosion resistance, strength, fracture toughness and fatigue life ensures that a bearing will function reliably within an application's operational and environmental parameters. During the material selection process, these characteristics are weighed against an application's specific conditions of temperature, load and corrosiveness.

The most important result of material selection is a bearing's longevity. Since different materials possess varying amounts of fatigue life, each alloy is assigned a life adjustment factor which is determined through empirical testing. This value provides a basis for calculating a dependable bearing-life estimate. The life adjustment factors for various bearing steels are listed on page 45.

Materials Processing

NHBB maintains exacting metallurgical control of all materials from the originating mill through all manufacturing processes. Materials are heat-treated and tempered in-house under controlled atmospheres to bring about the uniform grain structure and specific hardness appropriate for the intended application.

Carburizing

HiTech continually investigates the latest in materials technology, alloying techniques and heat-treat methods in order to design and manufacture more complex bearing components for the aerospace market. One recent development is the capability to carburize and case harden M50 NiL and other special alloys.

Continual development in gas turbine engine technology is leading to engines running at greater speeds and temperatures. These engines require bearings that are capable of enduring increased demands. When engines run at high speeds and elevated temperatures, the bearing rings increase in diameter because of centrifugal forces and thermal expansion.

In order to keep the inner ring fixed to the shaft, a greater press fit at ambient temperatures is required. However, the tighter press fit of the inner ring causes high tensile stresses within the bearing. A typical through-hardened bearing material such as M50 would crack under these conditions. An excellent solution to this problem is the use of a carburized steel alloy.

Carburizing is a heat-treat process where alloys with low carbon content are exposed to a carbon rich atmosphere at an elevated temperature. Carbon diffuses into the exposed surfaces of the ring. The ring is then heat-treated to the desired surface hardness while leaving the carbon-deficient core relatively soft.



NHBB's vacuum carburizing furnace.

Finished carburized alloys have a thin outer case, with hardness values comparable to M50, which provide the needed rolling contact fatigue properties. In contrast, the inner core of the carburized ring is relatively soft and ductile, with desirable fracture toughness properties that allow the bearing to tolerate high internal tensile stresses. These characteristics create a tougher bearing that is well suited for tight press fits or highly loaded flanges.

Materials Laboratory

Our Materials Laboratory is specifically designed and equipped to perform complex chemical, metallurgical and visual analyses of the many component parts in ball and roller bearings. Alloy composition is determined with X-ray diffraction spectrography and nondestructive test methods. Metallurgical studies are conducted with a metallograph, which performs microstructure photography at magnifications from 25 to 2000 times, and microhardness testers, which investigate surface effects and alloy homogeneity. The lab also utilizes a scan electron microscope (SEM) to inspect topographies of materials. The SEM has a magnification range that encompasses that of optical microscopy and extends it to the nanoscale.

Internal Bearing Geometry

When establishing the free state internal bearing geometry for both ball and roller bearings, the specific bearing application details must be carefully considered. These include the bearing loads (radial, axial and moment), speeds, operating temperature range, the specific geometry of the housing and shaft, their fits and the materials of which they are made.

Proper bearing function is dependent on all of these variables. The extremes of each variable must be accounted for in the bearing design to ensure that the maximum and minimum installed internal bearing geometries result in optimal running conditions and maximum bearing life. Consult with NHBB's Applications Engineering department for assistance with these special design details.

BALL BEARINGS



For any given bearing load in a ball bearing, internal stresses can be somewhat controlled by affecting the geometric relationship between the balls and raceways. When running under a load, force is transmitted from one bearing ring to the other through the ball set. Since the contact area between each ball and the rings is relatively small, even moderate loads can produce stresses of tens or even hundreds of thousands of pounds per square inch. Because internal stress levels have such an important effect on bearing life and performance, internal geometry must be carefully chosen for each application in order for bearing loads to be distributed properly.

Raceway, Track Diameter and Track Radius

The raceway in a ball bearing is the circular groove formed in the outside surface of the inner ring and in the inside surface of the outer ring. When the rings are aligned, these grooves form a circular track that contains the ball set.

The track diameter and track radius are two dimensions that define the configuration of each raceway. Track diameter is the measurement of the diameter of the imaginary circle running around the deepest portion of the raceway, whether it is an inner or outer ring. This measurement is made along a line

perpendicular to, and intersecting with, the axis of rotation. Track radius describes the cross section of the arc formed by the raceway groove. It is measured when viewed in a direction perpendicular to the axis of rotation. In the context of ball bearing terminology, track radius has no mathematical relationship to track diameter. The distinction between the two is shown here.

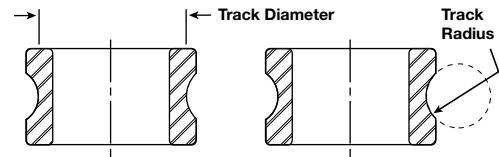

Radial and Axial Play

Most ball bearings are assembled in such a way that a slight amount of looseness exists between balls and raceways. This looseness is referred to as radial play and axial play. Radial play is the maximum distance that one bearing ring can be displaced with respect to the other in a direction perpendicular to the bearing axis when the bearing is in an unmounted state. Axial play, or end play, is the maximum relative displacement between the two rings of an unmounted ball bearing in the direction parallel to the bearing axis (shown here).

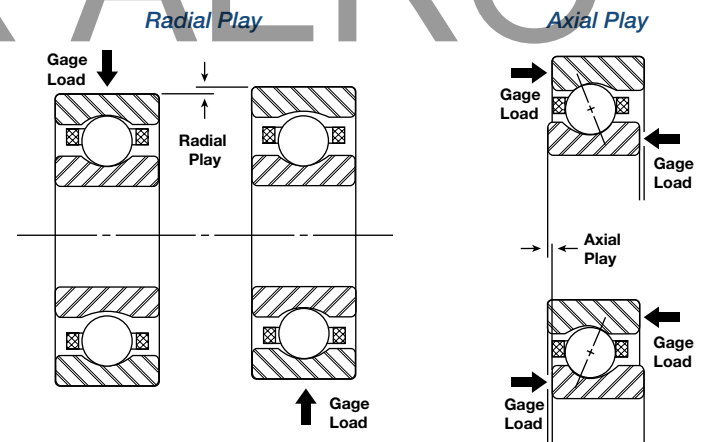

Since radial play and axial play are both consequences of the same degree of looseness between the components in a ball bearing, they bear a mutual dependence. While this is true, both values are usually quite different in magnitude. Radial play can often vary between .0002" and .002", while axial play may range anywhere from .001" to .020".

In most ball bearing applications, radial play is functionally more critical than axial play. While radial play has become the standard purchasing specification, users may also specify axial play requirements. It must be kept in mind, however, that the values of radial play and axial play for any given bearing design are mathematically interdependent.

Internal Bearing Geometry

These general statements can be made about ball bearing radial play:

1. The initial contact angle of the bearing is directly related to radial play—the higher the radial play, the higher the contact angle.
2. For support of pure radial loads, a low contact angle is desirable.
3. Where thrust loading is predominant, a higher contact angle (or radial play) is necessary.
4. Radial play is affected by any interference fit between the shaft and bearing I.D. or between the housing and bearing O.D.

Track Curvature

Track curvature is an expression that defines the difference between the arc of the raceway's track radius and the arc formed by the profile of the slightly smaller ball that runs in that raceway. It is simply the track radius of a bearing raceway expressed as a percentage of ball diameter. This number is a convenient index of "fit" between the raceway and ball, and is always slightly greater than the corresponding arc of the ball.

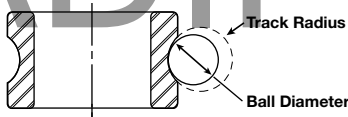

Track curvature values typically range from approximately 52% to 58%. The lower percentage, tight fitting curvatures are useful in applications where heavy loads are encountered while the higher percentage, loose curvatures are more suitable for torque-sensitive applications. Curvatures less than 52% are generally avoided because of excessive rolling friction that is caused by the tight conformity between the ball and raceway. Values above 58% are also avoided because of the high stress levels that can result from the small ball-to-raceway conformity at the contact area.

Contact Angle

The contact angle is the angle between a plane perpendicular to the ball bearing axis and a line joining the two points where the ball makes contact with the inner and outer raceways. The contact angle of a ball bearing is determined by its free radial play value, as well as its inner and outer track curvatures.

The contact angle of thrust-loaded bearings provides an indication of ball position inside the raceways. When a thrust load is

applied to a ball bearing, the balls will move away from the median planes of the raceways and assume positions somewhere between the deepest portions of the raceways and their edges. The following drawing illustrates the concept of contact angle by showing a cross sectional view of a ball bearing that is loaded in pure thrust.

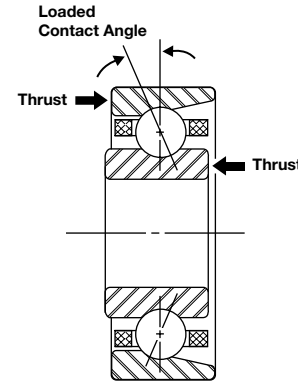

Free Angle of Misalignment

As a result of axial and radial play, which is purposely permitted to exist between the components of most ball bearings, the inner ring can be tilted a small amount in relation to the outer ring. This displacement is called free angle of misalignment. The amount of misalignment allowable in a given ball bearing is determined by its radial play and track curvature values. The misalignment capability of a bearing can have positive practical significance because it enables a ball bearing to accommodate small dimensional variations that may exist in associated shafts and housings. The performance of a misaligned bearing will be degraded to a certain extent, but for slight misalignments under reasonably light loads the effects will not be significant in most cases. This concept is shown below. In general, the misalignment a bearing is subjected to due to the shaft and housing's physical arrangement should never exceed the bearing's free angle of misalignment.

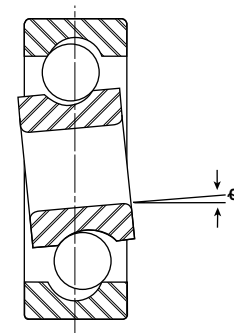

Internal Bearing Geometry

ROLLER BEARINGS



Radial Play

Radial play in a roller bearing is similar to that of a ball bearing, where they are assembled in such a way that a slight amount of looseness exists between rollers and raceways. As with ball bearings, radial play is the maximum distance that one bearing ring can be displaced with respect to the other in a direction perpendicular to the bearing axis when the bearing is in an unmounted state (shown here).

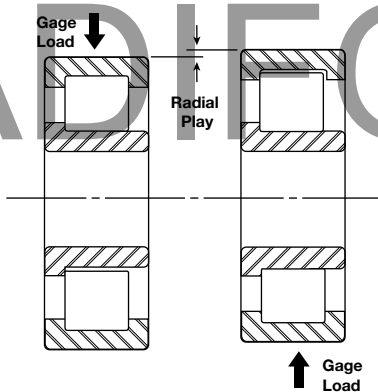

Some general statements can be made about roller bearing radial play:

1. Roller bearings are used for support of predominantly radial loads. Minimal thrust loading is tolerable, with a general guideline being 10% of the radial load.
2. Ideally, a roller bearing will perform best with a minimum installed radial play. This ensures that the load is distributed among the maximum number of roller elements, thereby minimizing the stresses.
3. Radial play is affected by any interference fit between the shaft and bearing I.D. or between the housing and bearing O.D.

Roller End Play

With roller bearings, roller end play (a.k.a. axial play or roller to guide flange clearance) is completely independent of radial play. Roller end play is the maximum relative displacement of the roller element within the confines of the double guide flanged (u-shaped) ring. Close attention and control of end play is required to manage roller skewing and to provide for optimum tracking at all loads and speeds.

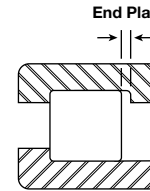

Free Angle of Misalignment

As with ball bearings, roller bearings have some capacity for misalignment. As a result of the previously described looseness, or play, which is purposely permitted to exist between the bearing components, the inner ring can be tilted a small amount in relation to the outer ring. This displacement is called free angle of misalignment. The amount of misalignment allowable in a given roller bearing is determined by its radial play, end play, guide flange angle and roller element geometry, namely the roller flat length and crown radius values (turn to page 43 for more information). Again, the misalignment capability of a roller bearing can also have positive practical significance because it enables the bearing to accommodate small dimensional variations that may exist in associated shafts and housings. The performance of a misaligned roller bearing will be degraded to a certain extent, but for slight misalignments under reasonably light loads, the effects will not be significant in most cases. In general, the misalignment a bearing is subjected to should never exceed the bearing's free angle of misalignment.

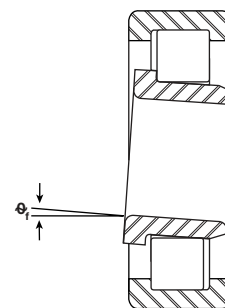

Internal Bearing Geometry

Calculating Radial Play, Axial Play and Contact Angle

Radial Play

$$P_D = 2Bd (1 - \cos \beta_0)$$

$$P_D = 2Bd - \sqrt{(2Bd)^2 - P_E^2}$$

Axial Play

$$P_E = 2Bd \sin \beta_0$$

$$P_E = \sqrt{4BdP_D - P_D^2}$$

Contact Angle

$$\beta_0 = \cos^{-1} \frac{2Bd - P_D}{2Bd}$$

$$\beta_0 = \sin^{-1} \frac{P_E}{2Bd}$$

P_D = Radial play

P_E = Axial play

β_0 = Contact angle

B = Total curvature = $(f_j + f_o - 1)$

f_j = Inner ring curvature*

f_o = Outer ring curvature*

d = Ball diameter

* Expressed as the ratio of race radius to ball diameter.

Analyzing an Application's Impact on Installed Radial Play

Once a preliminary value for radial play has been specified, it is important to analyze how mounting and operating conditions will affect the internal clearance within the bearing. The factors to consider include interference fits, material properties, temperature differentials, and high rotational speeds.

- Interference Fits:** Press fits reduce radial play by causing either the inner or outer ring to deflect when the bearing is installed. While the force generated by the interference fit is absorbed by both components (i.e., shaft and inner ring), the amount of deflection depends on the amount of interference, the properties of the materials and the configuration of the shaft or housing. For example, a solid shaft made of a stiff material will deflect the inner ring more than a hollow shaft made of a flexible material.
- Mating Materials:** A bearing's installed internal clearance is affected when mating components are made from materials that expand at different rates when subject to the same temperatures. When the rates of expansion are drastically different—e.g., the housing expands at twice the rate of the bearing's outer ring—the extremes of the operating temperature range could result in an unacceptable press fit and subsequent loss of radial play.
- Nonuniform Operating Temperatures:** Occasionally, a bearing's inner and outer rings experience different operating temperatures. When this happens, the rings will expand by different amounts, thus altering the bearing's internal clearance.
- Centrifugal Force:** High operating speeds generate centrifugal forces that can cause a bearing's rotating ring to expand. The result could affect internal clearance.

Prior to finalizing the design, it is necessary to determine the extent to which the above factors will impact the bearing's internal geometry and adjust the specified radial play accordingly.

Roller Bearing Features

NHBB manufactures cylindrical roller bearings in a wide range of sizes, designs and configurations. The tables and diagrams on this page illustrate some typical specifications for rings and rollers. We also have the capability to design and manufacture complex roller bearings with custom features, such as puller grooves, mounting flanges and anti-rotation devices (turn to page 33, the section titled Special Products, to learn more). Please contact NHBB's Applications Engineering department to discuss specific requirements for your application.

Roller Tolerances

DIAMETER & LENGTH	EXAMPLES		CORNER (IN.)
	CROWN DROP (IN.)	FLAT LENGTH (IN.)	
5 mm	Min: 0.0001 Max: 0.0003	Min: 0.050 Max: 0.130	0.012 – 0.018
22 mm	Min: 0.00070 Max: 0.00096	Min: 0.300 Max: 0.540	0.030 – 0.040

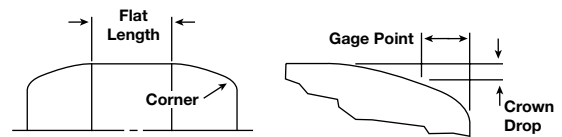

Roller Bearing Configurations

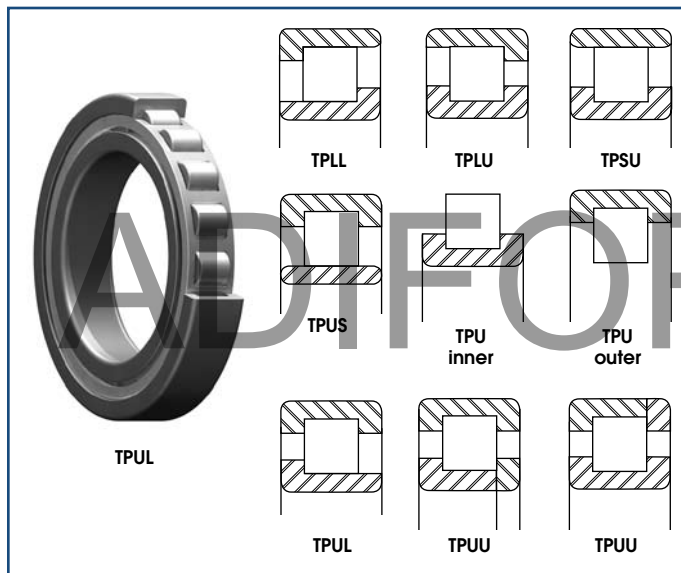

Roller Ring Standards

FEATURES	STANDARD
Guide Flanges:	
- Surface finish	10 R _a
- Layback angle tolerance	0.5° – 1°
- Runout to ring face	0.0003 in.
- Roller end clearance tolerance	0.0010 in.
Roller Paths:	
- Surface finish	6 R _a
- Straightness	0.000050 in.
- Wall thickness variation to I.D./O.D.	0.000300 in.

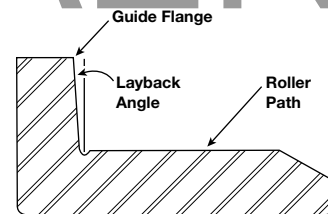

Cage/Roller Retention Comparison



CAGE STYLE	METHOD OF MANUFACTURE	CONTROL OF ROLLER DROP	REUSE AFTER DISASSEMBLY	NDT INSPECTION	MANUFACTURING COMPLEXITY
Roll Formed	Prior to assembly, cage is "roll formed" to create retention	Yields a relatively high roller drop as a function of roller diameter	Yes	All methods	Low
Line Staked	After rollers are in place, line stake tool forms retention	Tab is formed after assembly for close control of roller drop	No	Visual only (Disassembly not possible)	Moderate
Fully Machined	Roller retention is formed during broaching	Yields a relatively high roller drop as a function of roller diameter	Yes	All methods	High

Load Ratings and Bearing Life

The load ratings in this catalog are based on ANSI/ABMA Standards 9 and 11. These standards specify the accepted methods for calculating load ratings and fatigue life of ball and cylindrical roller bearings. Since a multitude of variables may affect these calculations, they should be used for baseline estimates only. Load ratings for your application's specific operating conditions should be calculated before making a final bearing choice.

Basic Dynamic Load Rating

The Basic Load Rating (C) for a radial or angular contact ball bearing is a calculated constant radial load which a bearing with a stationary outer ring can theoretically endure for a rating life of 1,000,000 revolutions of the inner ring. The ratings shown in this catalog are defined by ANSI/ABMA Standard 9 and Standard 11. The ratings for noncatalog bearings may be determined by referring to this standard.

Static Load Rating

A static load is a load acting on a nonrotating bearing. Experience shows that a total permanent deformation of 0.0001 of the rolling element diameter, at the center of the most heavily loaded rolling element/raceway contact, can be tolerated in most bearing applications without the bearing operation being impaired. The basic static load rating is, therefore, that load which produces the above deformation. As with the dynamic load ratings, the static rating determinations can be found in ANSI/ABMA Standard 9 and Standard 11.

Rating Life

Bearing fatigue life is a baseline estimate of the number of revolutions or hours that a bearing will operate before failing. The principal factor at play is metal fatigue, so failure is defined by the presence of spalling or flaking on a bearing's raceways. Since, in reality, identical bearings operating under identical conditions fail at unpredictable intervals, and since there is no way to predict the actual life of a specific bearing, the industry utilizes a statistical formula to calculate rating life. The calculations shown in the next column involve many parameters and are based on historical test data.

Reliability—L₁₀

The standard value L₁₀ equals the total number of revolutions that 90% of a group of identical bearings will theoretically meet or exceed. For a single bearing, L₁₀ also refers to the life associated with 90% reliability. The life which 50% of the group of bearings will meet or exceed (median life, or L₅₀) is usually no greater than five times the rating life (refer to the table under Life Adjustment Factors on page 45).

Basic Equations

Ball Bearings

$$L \text{ (cycles)} = (C/P_r)^3 \times a_1 \times a_2$$

Roller Bearings

$$L \text{ (cycles)} = (C/P_r)^{10/3} \times a_1 \times a_2$$

Convert to Hours of Operation

$$L \text{ (hours)} = 1,000,000/N \times 60$$

$$L \text{ (cycles)} = \text{Cycles (x 1 million)}$$

C = Dynamic load rating

P_r = Equivalent radial load

a₁ = Reliability adjustment factor

a₂ = Material adjustment factor

N = rpm

Calculating Equivalent Radial Load

More often than not, bearings with primarily radial loads are subject to some axial forces. When the magnitude of the axial component of the load is greater than a negligible value, it is helpful to translate the combined radial and axial load into a radial load so that the basic life equation may be used. This radial load, known as the equivalent radial load, is defined as that constant stationary radial load which, if applied to a rotating inner ring, would give the same life as that which the bearing will attain under the actual conditions of load and rotation. For conventional bearing types other than those with filling notches, the equivalent radial loads are given by the maximum of the two values where:

$$a) P_r = V F_r$$

$$b) P_r = X V F_r + Y F_a$$

V is a rotation factor

X is a radial factor

Y is a thrust factor

F_r is the radial load

F_a is the axial load

Consult the table on page 45 for determining values X, Y and e. In all series, the rotational factor V is 1.0 for inner ring rotation and 1.2 for outer ring rotation with respect to load. The factor e (last column) represents the ratio of F_a/V F_r for which the two equations are equal. If the ratio of loads is such that F_a/V F_r ≤ e, then formula (a) is used; if F_a/V F_r > e, then formula (b) is used.



Load Ratings and Bearing Life

Life Adjustment Factors

When a more conservative approach than conventional rating life (L_{10}) is desired, the ABMA offers a means for such estimates. The table below provides selected multipliers for calculating failure rates down to 1% (L_1).

RELIABILITY	RATING LIFE	LIFE ADJUSTMENT FACTOR
90	L_{10}	1.00
95	L_5	0.62
96	L_4	0.53
97	L_3	0.44
98	L_2	0.33
99	L_1	0.21

Material Factors

Certain materials are proven to have greater fatigue life than others operating under identical conditions. The theoretical L_{10} dynamic life is based on air-melt steel and standard ABMA formulas. The life adjustment factors for materials frequently used are shown here:

MATERIAL	FACTOR
M50 NiL	20
M50	10
52100 VIM/VAR	7
52100 CEVM	5
BG42®	3
52100	1
440C	0.8

Other Life Adjustment Factors

The conventional rating life often has to be modified as a consequence of application abnormalities. The following conditions all have the practical effect of modifying the ideal theoretical rating life of L_{10} :

- Vibration and/or shock-impact loads
- Angular misalignment
- High speed
- Operating at elevated temperatures
- Lubricant effects

NHBB can provide reliable bearing life estimates based on semi-empirical data to assist in accurately forecasting bearing life.

Factors X, V and Y

BEARING TYPE	$\frac{F_a}{ZD^2}$ UNITS LBS, IN.	IN RELATION TO THE LOAD THE INNER RING IS:		SINGLE ROW BEARINGS $\frac{F_a}{VFr} > e$		e
		ROTATING V	STATIONARY V	X	Y	
Radial deep groove ball bearings	25	1	1.2	0.056	2.30	0.19
	50				1.99	0.22
	100				1.71	0.26
	150				1.55	0.28
	200				1.45	0.30
	300				1.31	0.34
	500				1.15	0.38
	750				1.04	0.42
1,000	1.00	0.44				
Angular contact ball bearings with contact angle: 5°	25	1	1.2	0.56	2.30	0.23
	50				1.99	0.26
	100				1.71	0.30
	150				1.55	0.34
	200				1.45	0.36
	300				1.31	0.40
	500				1.15	0.45
	750				1.04	0.50
1,000	1.00	0.52				
10°	25	1	1.2	0.46	1.88	0.29
	50				1.71	0.32
	100				1.52	0.36
	150				1.41	0.38
	200				1.34	0.40
	300				1.23	0.44
	500				1.10	0.49
	750				1.01	0.54
1,000	1.00	0.54				
15°	25	1	1.2	0.44	1.47	0.38
	50				1.40	0.40
	100				1.30	0.43
	150				1.23	0.46
	200				1.19	0.47
	300				1.12	0.50
	500				1.02	0.55
	750				1.00	0.56
1,000	1.00	0.56				
20°		1	1.2	0.43	1.00	0.57
25°		1	1.2	0.41	0.87	0.68
30°		1	1.2	0.39	0.76	0.80
35°		1	1.2	0.37	0.66	0.95
40°		1	1.2	0.35	0.57	1.14

Additional nomenclature is as follows:

- Z is the number of balls
- D is the ball diameter in inches

Values of X, Y and e for load or contact angle other than shown are obtained by linear interpolation.

BG42® is a registered trademark of Latrobe Specialty Steel Company.

Preload and Duplex Bearings

The initial axial load placed on a set of bearings during installation is defined as preload. Preloading facilitates precise control over the operating geometry of the bearing's mating parts, a useful function in applications where axial and radial movement must be held within critical limits. The specific functional attributes include:

- Removal of the free axial and radial play for precise shaft positioning. With the removal of free play, the geometries of the bearings dictate the radial and axial run-outs;

- Establishment of a precise amount of axial and radial stiffness. The spring rates in the axial and radial directions are constant as long as the preload is maintained;
- Minimization of ball skidding. Properly designed preloading keeps the balls under load in high speed or rapid acceleration/ deceleration operation;
- Allowance of load sharing between bearings. Increased axial capacities can be realized using tandem duplexes.

Methods:

Bearings may be preloaded using one of the following approaches:

1. Specify factory "built-in" preload sets. Since each set is checked for preload level as it is built, these duplex bearings provide the greatest control over preload. The clamping load can be applied either with a single nut tightened to a specific torque, or a clamping ring with multiple screws tightened to a prescribed torque.
2. Use shims and/or spacers to provide the preload deflection offsets. The appropriate faces can then be clamped as above to provide the preload. This method can result in wide ranges of preload, as lengths vary with shims or spacers.
3. Use compression springs (wave washers, Belleville washers, etc.) to apply the initial axial load to the set. Due to tolerance stack-ups, this method is not very precise. The spring's placement (with its lower spring rate) is critical for preventing preload unloading due to external axial loads.

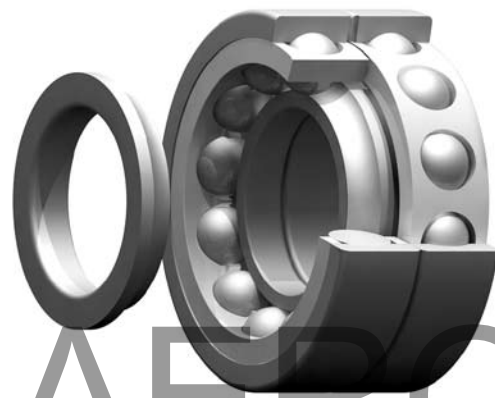

Preload and Duplex Bearings

Duplex Bearing Configurations

DB (back to back): The outboard faces of this set's inner rings are loaded, creating opposing contact angles that diverge to the bearing axis. Factory "built-in" offsets in the unloaded state provide the proper preload deflection when the inner races are clamped together. This configuration has higher moment stiffness than the DF configuration (under the same preload, DB and DF have identical radial and axial stiffness rates). Use DB when the shaft temperature is higher than the housing temperature, as this configuration minimizes preload build-up due to differential expansions, and reduces heat buildup in the bearings.

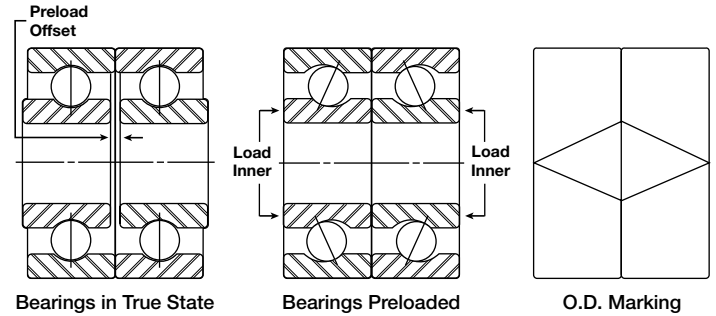

DF (face to face): The outboard faces of this set's outer rings are loaded, creating opposing contact angles that converge to the bearing axis inside the bearing envelope. Factory "built-in" offsets in the unloaded state provide the proper preload when the outer races are clamped together. This configuration has lower moment stiffness than DB, which allows for some misalignment. Use DF when the housing temperature is higher than the shaft temperature.

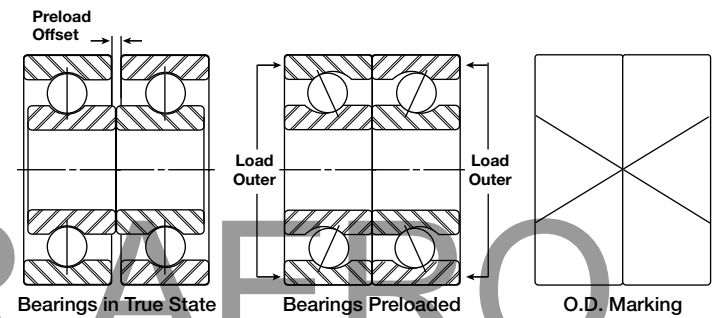

DT (tandem): The contact angles of the bearings are oriented in the same direction, allowing for increased load sharing in the axial direction. DT has the same radial stiffness (with equal preload) as the DB or DF configurations, but its axial stiffness is twice that of either pair with the same preload. Factory "built-in" offsets in the unloaded state provide the proper preload when the outer race on one side and the inner race on the opposite side are loaded. To achieve a preloaded condition, DT requires an opposing bearing or bearing-set.

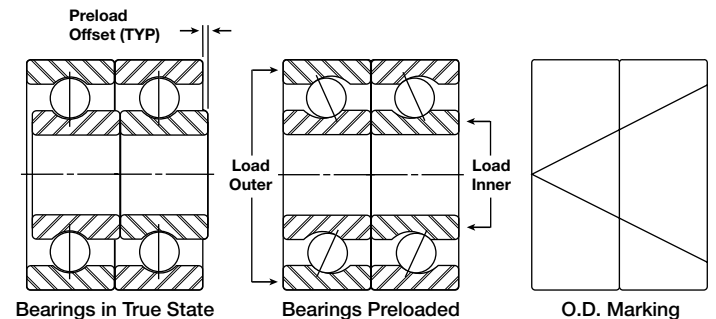

DU (universal): The faces are flush on both sides with the factory "built-in" preload, so this configuration can be oriented in any configuration: DB, DF or DT.

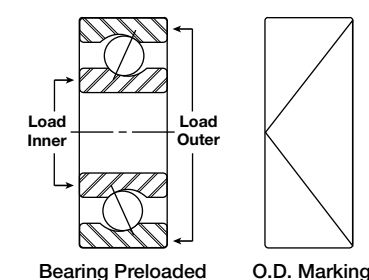

Shaft and Housing Fits

Establishing accurate shaft and housing fits is critical to achieving the best possible bearing performance. Fits that are too loose or too tight can create conditions that lead to premature bearing failure. Under certain conditions, overly loose fits can lead to corrosion of the shaft or bore, excessive wear, poor bearing rotation, and excessive vibration and noise. Exceedingly tight fits often cause large mounting and dismounting forces, unwanted preload, overheating, and a reduction in radial play.

Shaft and housing fits are governed by the assembly's specific operating requirements and conditions. The various factors to consider include the type and amount of load, operating temperature, running accuracy requirements, material composition and machining tolerances of mating components, and the size and type of bearing specified.

Generally speaking, the rotating ring of the bearing requires an interference fit with either the shaft or housing, and the nonrotating ring demands a slight loose fit with its mating component.

Thin cross section bearings, such as NHBB's thin section and torque tube series, are inherently more sensitive to shaft and housing fits than metric ball and roller bearings. In most

conditions a line-to-line-to-loose fit is more appropriate for thin cross sections. Heavier cross section bearings require tighter fits than light cross section bearings. In either case, extreme interference fits should only be used in conjunction with larger internal clearance in order to accommodate the subsequent loss of radial play.

The specific recommendations for shaft and housing fits for metric series radial ball and roller bearings are covered under ABMA Standard 7. The standards do not apply to inch series bearings, so consult NHBB's Applications Engineering department for assistance.

The following tables provide fit recommendations for a variety of operating conditions and load magnitudes. Table I specifies the load classification. Tables II and III specify standard shaft and housing tolerance classifications. Tables IV and V on pages 50 and 51 identify the specific fit tolerances for NHBB's metric series ball and cylindrical roller bearings up to 12" O.D. For help with verifying the correct fit for your application, or to request a complete bearing optimization, please consult NHBB's Applications Engineering department.

ADIFOR AERO

Determining Load Classification

To determine whether a load is either light, normal, or heavy, divide an application's equivalent radial load (P_r) by the bearing's dynamic radial load rating (C_r). Compare the results with Table I. See page 44 for a definition and method for calculating equivalent radial load.

Table I: Load Classification

	LIGHT	NORMAL	HEAVY
Ball Bearings	0.0 – 0.06	0.06 – 0.12	0.12 – 0.40
Cylindrical Roller Bearings	0.0 – 0.07	0.07 – 0.18	0.14 – 0.40

Diagram of Fit Tolerances*

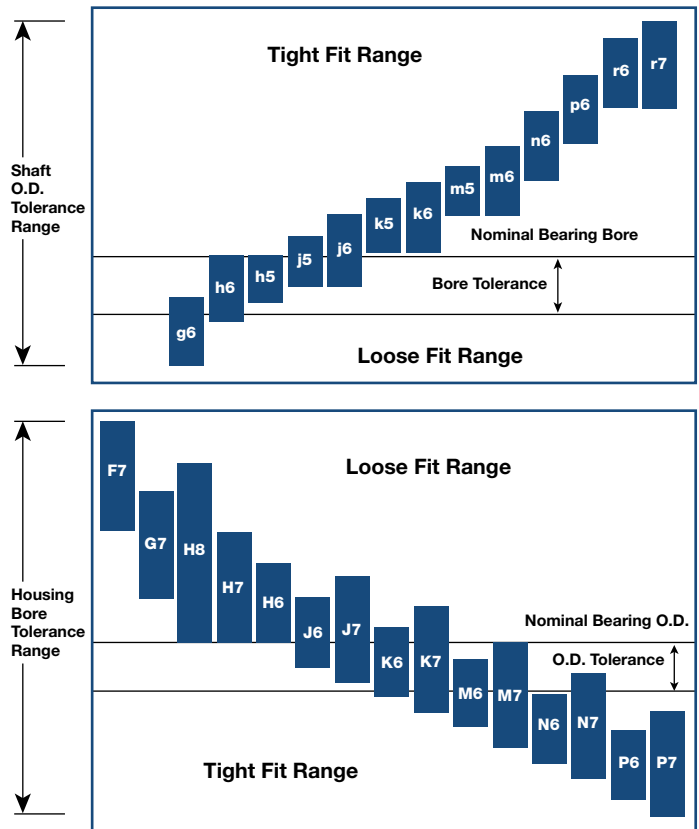

*Copyright American Bearing Manufacturers Association, Inc. All rights reserved. Used with permission.



Shaft and Housing Fits

Table II: Classification for Shaft Tolerances*

DESIGN & OPERATING CONDITIONS			BALL BEARINGS			CYLINDRICAL ROLLER BEARINGS		
ROTATIONAL CONDITIONS	INNER RING AXIAL DISPLACEABILITY	RADIAL LOADING	d		TOLERANCE CLASSIFICATION	d		TOLERANCE CLASSIFICATION ●
			OVER	INCL.		OVER	INCL.	
Inner ring rotating in relation to load or load direction is indeterminate		Light	0 0.71	0.71 All	h5 j6 ■	0 1.57 5.51 12.60 19.70	1.57 5.51 12.60 19.70 All	j6 ■ k6 ■ m6 ■ n6 p6
		Normal	0 0.71	0.71 All	j5 k5	0 1.57 3.94 5.51 12.60 19.70	1.57 3.94 5.51 12.60 19.70 All	k5 m5 m6 n6 p6 r6
		Heavy	0.71 3.94	3.94 All	k5 m5	0 1.57 2.56 5.51 7.87 19.70	1.57 2.56 5.51 7.87 19.70 All	m5 m6 n6 p6 r6 r7
Inner ring stationary in relation to load direction	Inner ring must be easily axially displaceable	Light, normal or heavy	All sizes		g6	All sizes		g6
	Inner ring need not be easily axially displaceable	Light, normal or heavy	All sizes		h6	All sizes		h6

Dimensions are in inches.

For metric radial ball and roller bearings of tolerance classes ABEC 1 and RBEC 1.

● Values relate to solid steel shafts only. Tighter fits may be needed for hollow or nonferrous shafts.

■ Select higher classification for greater accuracy (e.g., j5 for j6).

Table III: Classification for Housing Tolerances*

DESIGN AND OPERATING CONDITIONS				TOLERANCE CLASSIFICATION ●
ROTATIONAL CONDITIONS	LOADING	OTHER CONDITIONS	OUTER RING AXIAL DISPLACEABILITY	
Outer ring stationary in relation to load direction	Light, normal or heavy	Heat input through shaft	Outer ring easily axially displaceable	G7 ▲
		Housing split axially		H7 ■
	Shock with temporary complete unloading	Housing not split axially		H6 ■
Load direction indeterminate	Light	Split not recommended	Transitional range ◆	J6 ■
	Normal or heavy			K6 ■
Heavy shock	Light			Outer ring not easily axially displaced
Outer ring rotating in relation to load direction	Normal or heavy	N6 ■		
	Heavy	Thin wall housing not split	P6 ■	

For metric radial ball and roller bearings of tolerance classes ABEC 1 and RBEC 1.

● Values relate to cast iron steel housings. Tighter fits may be needed for nonferrous alloys.

■ Substitute lower classifications where wider tolerances are allowed. Please consult the factory.

▲ Use F7 if temperature differential between inner and outer ring of a large bearing is greater than 10 °C.

◆ The outer ring may either be tight or loose in the housing.

*Copyright American Bearing Manufacturers Association, Inc. All rights reserved. Used with permission.

Shaft and Housing Fits

Table IV: Bore Fit Tolerances*

d			TOLERANCE CLASSIFICATIONS													
OVER	INCLUDING	TOLERANCE	g6		h6		h5		j5		j6		k5		k6	
			SHAFT	FIT	SHAFT	FIT	SHAFT	FIT	SHAFT	FIT	SHAFT	FIT	SHAFT	FIT	SHAFT	FIT
0.1181	0.2362	0 -3	-2 -5	5L 1T	0 -3	3L 3T	0 -2	2L 3T	+1 -1	1L 4T	+2 -1	1L 5T	+2 0	0 5T		
0.2362	0.3937	0 -3	-2 -6	6L 1T	0 -4	4L 3T	0 -2	2L 3T	+2 -1	1L 5T	+3 -1	1L 6T	+3 0	0 6T		
0.3937	0.7087	0 -3	-2 -7	7L 1T	0 -4	4L 3T	0 -3	3L 3T	+2 -1	1L 5T	+3 -1	1L 6T	+4 0	0 7T		
0.7087	1.1811	0 -4	-3 -8	8L 1T	0 -5	5L 4T			+2 -2	2L 6T	+4 -2	2L 8T	+4 +1	1T 8T		
1.1811	1.9685	0 -4.5	-4 -10	10L 0.5T	0 -6	6L 4.5T			+2 -2	2L 6.5T	+4 -2	2L 8.5T	+5 +1	1T 9.5T	+7 +1	1T 11.5T
1.9685	3.1496	0 -6	-4 -11	11L 2T	0 -7	7L 6T			+2 -3	3L 8T	+5 -3	3L 11T	+6 +1	1T 12T	+8 +1	1T 14T
3.1496	4.7244	0 -8	-5 -13	13L 3T	0 -9	9L 8T			+2 -4	4L 10T	+5 -4	4L 13T	+7 +1	1T 15T	+10 +1	1T 18T
4.7244	7.0866	0 -10	-6 -15	15L 4T	0 -10	10L 10T			+3 -4	4L 13T	+6 -4	4L 16T	+8 +1	1T 18T	+11 +1	1T 21T
7.0866	7.8740	0 -12	-6 -17	17L 6T	0 -11	11L 12T			+3 -5	5L 15T	+6 -5	5L 18T	+9 +2	2T 21T		
7.8740	8.8583	0 -12	-6 -17	17L 6T	0 -11	11L 12T			+3 -5	5L 15T	+6 -5	5L 18T	+9 +2	2T 21T		
8.8583	9.8425	0 -12	-6 -17	17L 6T	0 -11	11L 12T			+3 -5	5L 15T	+6 -5	5L 18T	+9 +2	2T 21T		
9.8425	11.0236	0 -14	-7 -19	19L 7T	0 -13	13L 14T			+3 -6	6L 17T	+6 -6	6L 20T	+11 +2	2T 25T		

Dimensions are in inches.

Shaft deviations and resultant fits are in 0.0001 inches.

Table V: Housing Fit Tolerances*

d			TOLERANCE CLASSIFICATIONS															
OVER	INCLUDING	TOLERANCE	F7		G7		H8		H7		H6		J6		J7		K6	
			HOUSING	FIT	HOUSING	FIT	HOUSING	FIT	HOUSING	FIT	HOUSING	FIT	HOUSING	FIT	HOUSING	FIT	HOUSING	FIT
0.3937	0.7087	+0 -3	+6 +13	16L 6L	+2 +9	12L 2L	0 +11	14L 0	0 +7	10L 0	0 +4	7L 0	-2 +2	5L 2T	-3 +4	7L 3T	-4 +1	4L 4T
0.7087	1.1811	+0 -3.5	+8 +16	19.5L 8L	+3 +11	14.5L 3L	0 +13	16.5L 0	0 +8	11.5L 0	0 +5	8.5L 0	-2 +3	6.5L 2T	-4 +5	8.5L 4T	-4 +1	4.5L 4T
1.1811	1.9685	+0 -4.5	+10 +20	24.5L 10L	+4 +13	17.5L 4L	0 +15	19.5L 0	0 +10	14.5L 0	0 +6	10.5L 0	-2 +4	8.5L 2T	-4 +6	10.5L 4T	-5 +1	5.5L 5T
1.9685	3.1496	+0 -5	+12 +24	29L 12L	+4 +16	21L 4L	0 +18	23L 0	0 +12	17L 0	0 +7	12L 0	-2 +5	10L 2T	-5 +7	12L 5T	-6 +2	7L 6T
3.1496	4.7244	+0 -6	+14 +18	34L 14L	+5 +19	25L 5L	0 +21	27L 0	0 +14	20L 0	0 +9	15L 0	-2 +6	12L 2T	-5 +9	15L 5T	-7 +2	8L 7T
4.7244	5.9055	+0 -7	+17 +33	40L 17L	+6 +21	28L 6L	0 +25	32L 0	0 +16	23L 0	0 +10	17L 0	-3 +7	14L 3T	-6 +10	17L 6T	-8 +2	9L 8T
5.9055	7.0866	+0 -10	+17 +33	43L 17L	+6 +21	31L 6L	0 +25	35L 0	0 +16	26L 0	0 +10	20L 0	-3 +7	17L 3T	-6 +10	20L 6T	-8 +2	12L 8T
7.0866	9.8425	+0 -12	+20 +38	50L 20L	+6 +24	36L 6L	0 +28	40L 0	0 +18	30L 0	0 +11	23L 0	-3 +9	21L 3T	-6 +12	24L 6T	-9 +2	14L 9T
9.8425	12.4016	+0 -14	+22 +43	57L 22L	+7 +27	41L 7L	0 +32	46L 0	0 +20	34L 0	0 +13	27L 0	-3 +10	24L 3T	-6 +14	28L 6T	-11 +2	16L 11T

Dimensions are in inches.

Housing deviations and resultant fits are in 0.0001 inches.

*Copyright American Bearing Manufacturers Association, Inc. All rights reserved. Used with permission.



Shaft and Housing Fits

Table IV: Bore Fit Tolerances*

d			TOLERANCE CLASSIFICATIONS											
OVER	INCLUDING	TOLERANCE	m5		m6		n6		p6		r6		r7	
			SHAFT	FIT	SHAFT	FIT	SHAFT	FIT	SHAFT	FIT	SHAFT	FIT	SHAFT	FIT
0.1181	0.2362	0 -3	+4 +2	2T 7T										
0.2362	0.3937	0 -3	+5 +2	2T 8T										
0.3937	0.7087	0 -3	+6 +3	3T 9T										
0.7087	1.1811	0 -4	+7 +3	3T 11T										
1.1811	1.9685	0 -4.5	+8 +4	4T 12.5T	+10 +4	4T 14.5T								
1.9685	3.1496	0 -6	+9 +4	4T 15T	+12 +4	4T 18T	+15 +8	8T 21T						
3.1496	4.7244	0 -8	+11 +5	5T 19T	+14 +5	5T 22T	+18 +9	9T 26T	+23 +15	15T 31T				
4.7244	7.0866	0 -10	+13 +6	6T 23T	+16 +6	6T 26T	+20 +11	11T 30T	+27 +17	17T 37T	+35 +26	26T 45T		
7.0866	7.8740	0 -12	+15 +7	7T 27T	+18 +7	7T 30T	+24 +12	12T 36T	+31 +20	20T 43T	+42 +30	30T 54T		
7.8740	8.8583	0 -12	+15 +7	7T 27T	+18 +7	7T 30T	+24 +12	12T 36T	+31 +20	20T 43T	+43 +31	31T 55T	+50 +31	31T 62T
8.8583	9.8425	0 -12	+15 +7	7T 27T	+18 +7	7T 30T	+24 +12	12T 36T	+31 +20	20T 43T	+44 +33	33T 56T	+51 +33	33T 63T
9.8425	11.0236	0 -14	+17 +8	8T 31T	+20 +8	8T 34T	+26 +13	13T 40T	+35 +22	22T 49T	+50 +37	37T 64T	+57 +37	37T 71T

Dimensions are in inches.
Shaft deviations and resultant fits are in 0.0001 inches.

Table V: Housing Fit Tolerances*

d			TOLERANCE CLASSIFICATIONS													
OVER	INCLUDING	TOLERANCE	K7		M6		M7		N6		N7		P6		P7	
			HOUSING	FIT	HOUSING	FIT	HOUSING	FIT	HOUSING	FIT	HOUSING	FIT	HOUSING	FIT	HOUSING	FIT
0.3937	0.7087	+0 -3	-5 +2	5L 5T	-6 -2	1L 6T	-7 0	3L 7T	-8 -4	1T 8T	-9 -2	1L 9T	-10 -6	3T 10T	-11 -4	1T 11T
0.7087	1.1811	+0 -3.5	-6 +2	5.5L 6T	-7 -2	1.5L 7T	-8 0	3.5L 8T	-9 -4	0.5T 9T	-11 -3	0.5L 11T	-12 -7	3.5T 12T	-14 -6	2.5T 14T
1.1811	1.9685	+0 -4.5	-7 +3	7.5L 7T	-8 -2	2.5L 8T	-10 0	4.5L 10T	-11 -5	0.5T 11T	-13 -3	1.5L 13T	-15 -8	3.5T 15T	-17 -7	2.5T 17T
1.9685	3.1496	+0 -5	-8 +4	9L 8T	-9 -2	3L 9T	-12 0	5L 12T	-13 -6	1T 13T	-15 -4	1L 15T	-18 -10	5T 18T	-20 -8	3T 20T
3.1496	4.7244	+0 -6	-10 +4	10L 10T	-11 -2	4L 11T	-14 0	6L 14T	-15 -6	0 15T	-18 -4	2L 18T	-20 -12	6T 20T	-23 -9	3T 23T
4.7244	5.9055	+0 -7	-11 +5	12L 11T	-13 -3	4L 13T	-16 0	7L 16T	-18 -8	1T 18T	-20 -5	2L 20T	-24 -14	7T 24T	-27 -11	4T 27T
5.9055	7.0866	+0 -10	-11 +5	15L 11T	-13 -3	7L 13T	-16 0	10L 16T	-18 -8	2L 18T	-20 -5	5L 20T	-24 -14	4T 24T	-27 -11	1T 27T
7.0866	9.8425	+0 -12	-13 +5	17L 13T	-15 -3	9L 15T	-18 0	12L 18T	-20 -9	3L 20T	-24 -6	6L 24T	-28 -16	4T 28T	-31 -13	1T 31T
9.8425	12.4016	+0 -14	-14 +6	20L 14T	-16 -4	10L 16T	-20 0	14L 20T	-22 -10	4L 22T	-26 -6	8L 26T	-31 -19	5T 31T	-35 -14	0 35T

Dimensions are in inches.
Housing deviations and resultant fits are in 0.0001 inches.

*Copyright American Bearing Manufacturers Association, Inc.
All rights reserved. Used with permission.

Seals and Shields

NHBB offers a variety of protective closures designed to retain lubricants and prevent contamination from reaching critical bearing surfaces. When specifying closures, consideration should be given to bearing width● and the compatibility of retainer and shield type to allow for appropriate clearance.

Depending on the requirements of your application, it may be necessary to customize a closure by modifying the types listed here. Please contact NHBB's Applications Engineering department for information about special designs that may be better suited to your particular application.

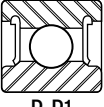

D, D1

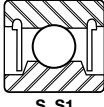

S, S1

Seal Types

Seals are generally used in high contamination environments where a positive closure is required, but they can increase torque and heat generation, which may affect operating speed limits.

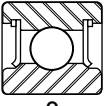

Q

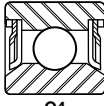

Q4

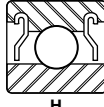

H

Shield Types

The shields shown left provide a barrier to gross contamination without unduly affecting speed and torque.

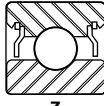

Z

Seals and Shields

TYPE	DESCRIPTION	MATERIAL	MAX. TEMP.	SPEED LIMIT (dN◆)	COMMENTS
D	Seal – removable	Nitrile rubber bonded to steel insert	250 °F	180,000	Positive contact, high torque, most effective in excluding contamination
D1	Seal – removable	Fluorocarbon rubber bonded to steel insert	400 °F	180,000	Positive contact, high torque, most effective in excluding contamination
Q	Seal with snap wire – removable	Glass reinforced PTFE*	600 °F	200,000	Positive contact, lower torque than D or D1, very effective in excluding contamination
Q4	Seal with outboard shield and snap wire – removable	Glass reinforced PTFE*, 300 series stainless steel	600 °F	200,000	Positive contact, lower torque than D or D1, very effective in excluding contamination
S	Seal – removable, noncontact	Nitrile rubber bonded to steel insert	250 °F	No influence on speed	Noncontact, no effect on bearing torque, less protection than D or Q
S1	Seal – removable, noncontact	Fluorocarbon rubber bonded to steel insert	400 °F	No influence on speed	Noncontact, no effect on bearing torque, less protection than D or Q
Z	Shield – removable with snap wire	300 series stainless steel	600 °F	No influence on speed	No effect on bearing torque, less protection than seal
H	Shield – nonremovable	300 series stainless steel	600 °F	No influence on speed	No effect on bearing torque, less protection than seal

◆dN = bore (in millimeters) x rpm.

*Polytetrafluoroethylene is a high-melt-temperature thermoplastic.

●Width dimensions noted in the product tables of this Design Guide are for open bearings. Please consult the factory to identify widths for bearings with closures. In NHBB's part numbering system, **RW** refers to radial bearings with cartridge widths (see page 7).

Cage Types

NHBB utilizes numerous cage types consisting of different materials, manufacturing processes and configurations in order to satisfy a diverse range of application requirements. A limited number of standard cage materials such as steel, bronze, phenolic and nylon are sufficient to cover a broad spectrum of speeds and operating temperatures. In high speed, high temperature, and highly corrosive conditions, it may be necessary to specify more specialized materials such as silicon-iron

bronze or steel with silver plating in order to improve performance and prolong bearing life. In high load conditions, the optimal solution may be a full ball complement—or cage-less—design. While the following information is a good starting point, our applications engineers are ready to assist you in selecting the most appropriate cage configuration for your specific application.

Cylindrical Roller Bearings

STYLE – POCKET TYPE	PILOTING SURFACE	†	DESIGN	MATERIAL (FABRICATION METHOD)	MAX. SPEED [1000 dN◆]	MAX. OPERATING TEMP.	UTILITY	LIMITATIONS	TYPICAL APPLICATIONS
1-piece, rectangular pocket, with roller retention Typical – retention feature located opposite piloting surface	Land	S		Steel – silver plate (machined)	3,000	900 °F (482 °C)	Higher speed/strength capability, corrosion resistant, lubricity	High cost	Mainshafts, gear boxes
		B		Leaded {80-10-10} bronze (machined)	1,000	350 °F (177 °C)	Moderate strength/speed capability	Moderate cost	Pumps and accessories
				Silicon-iron bronze (machined)	1,500	500 °F (260 °C)	High speed/strength capability	Moderate cost	Gear boxes
		P		PEEK● (molded)	1,000	500 °F (260 °C)	Light weight, high temperature/strength capability, tough, abrasion resistant	High cost, limited availability – consult factory	High reliability, aerospace – power transmission
1-piece, rectangular pocket No retention feature	Land	S		Steel – silver plate (machined)	3,000	900 °F (482 °C)	Higher speed/strength capability, corrosion resistant, lubricity	High cost	Mainshafts, gear boxes
		B		Leaded {80-10-10} bronze (machined)	1,000	350 °F (177 °C)	Moderate strength/speed capability	Moderate cost	Pumps and accessories
				Silicon-iron bronze	1,500	500 °F (260 °C)	High speed/strength capability	Moderate cost	Gear boxes
		P		PEEK● (molded)	1,000	500 °F (260 °C)	Light weight, high temperature/strength capability, tough, abrasion resistant	High cost, limited availability – consult factory	High reliability, aerospace – power transmission

Please note: Additional cage designs and materials are available. Please consult the factory for assistance.

† Typical nomenclature that corresponds to material type only. Other distinguishing features are defined according to a unique dash number. See Roller Bearing Part Numbering System on page 6.

S = Steel with silver plate

B = Bronze

P = Plastic

◆dN = bore (in millimeters) x rpm.

●PEEK = Polyetheretherketone, a high-melt-temperature thermoplastic.

Cage Types

Angular Contact, Gothic Arch and Fractured Race Ball Bearings

STYLE – POCKET TYPE	PILOTING SURFACE	†	DESIGN	MATERIAL (FABRICATION METHOD)	MAX. SPEED [1000 dN♦]	MAX. OPERATING TEMP.	UTILITY	LIMITATIONS	TYPICAL APPLICATIONS	
1-piece, cylindrical pocket	Land	ME		PEEK● (molded)	1,000	500 °F (260 °C)	Light weight, high temperature/strength capability, tough, abrasion resistant	High cost, limited availability – consult factory	High reliability, aerospace – power transmission	
	Inner Land	KM		Phenolic – linen base (machined)	1,500	300 °F (149 °C)	Quiet running, porous – can be impregnated with oil	Limited compatibility, hygroscopic, outgasses in a vacuum	Spindles, high speed motors, robotic joints	
	Outer Land	KV		PA■ – glass filled (molded)	750	300 °F (149 °C)	Quiet running, abrasion/impact resistant	Low cost/high volume, hygroscopic (3%), limited availability – consult factory	Motors, spindles, general purpose	
	Land	MX		Bronze▲ (machined)	1,500	500 °F (260 °C)	Thin cross section, higher ball groove shoulders, high speed/strength capability	High cost	Power transmission, aircraft accessories	
		M2		Steel – silver plate (machined)	3,000	900 °F (482 °C)	Higher speed/strength capability, corrosion resistant, lubricity	Higher cost	Aircraft accessories, high speed transmission	
1-piece, cylindrical pocket, with ball retention	Inner Land	MP		Leaded (80-10-10) bronze (machined)	1,000	350 °F (177 °C)	Moderate speed/strength capability	Moderate cost	Pumps, actuators, accessory gear boxes	
	Outer Land	MQ		Silicon-iron bronze (machined)	2,000	500 °F (260 °C)	High speed/strength capability	Higher cost	Gear boxes	
	Inner Land	B5		Steel – silver plate (machined)	3,000	900 °F (482 °C)	Higher speed/strength capability, corrosion resistant, lubricity	Higher cost	High reliability mainshaft bearings, gear boxes	
	Outer Land	B6		Phenolic – linen base (machined)	1,500	300 °F (149 °C)	Quiet running, porous – can be impregnated with oil	Limited compatibility, hygroscopic, outgasses in a vacuum	Motors, spindles	
	Typical – retention feature located opposite piloting surface	Inner Land		S3						
		Outer Land		S4						
		Outer Land		KS						

Please note: Additional cage designs and materials are available. Consult the factory for assistance.

† See page 7 for alphanumeric part number code.

♦ dN = bore (in millimeters) x rpm.

● PEEK = Polyetheretherketone is a high-melt-temperature thermoplastic.

■ PA = Polyamide (a.k.a. Nylon or Nylon 6/6) is a high-melt-temperature thermoplastic.

▲ Types other than 80-10-10 (leaded bronze) are assigned a special design (SD) number. See Ball Bearing Part Numbering System on page 7.

Cage Types

Radial Ball Bearings

STYLE – POCKET TYPE	PILOTING SURFACE	†	DESIGN	MATERIAL (FABRICATION METHOD)	MAX. SPEED [1000 dN◆]	MAX. OPERATING TEMP.	UTILITY	LIMITATIONS	TYPICAL APPLICATIONS
2-piece ribbon, spherical pocket (clinched)	Land	R		Steel (stamped)	150	900 °F (482 °C)	Compact – seal or shield clearance, low starting torque, low cost	Low to moderate speeds only, high wear rate, mis-registration	General purpose, industrial
	Ball	RD							
2-piece ribbon, spherical pocket (riveted)	Land	R4		Steel (stamped)	250	900 °F (482 °C)	Compact – seal or shield clearance, low starting torque, low cost	Moderate speed capability, high wear rate	Motors, generators
	Ball	R6							
2-piece ribbon, cylindrical pocket, skirted (riveted)	Inner Land	R5		Phosphor bronze (stamped)	1,000	400 °F (204 °C)	Higher speed/strength capability, stable – tolerates higher acceleration	Higher cost, ground land (ring) surfaces, limited availability – consult factory	Transmission, power units
	Outer Land	R7							
2-piece, cylindrical pocket (riveted)	Inner Land	B1		Leaded {80-10-10} bronze (machined)	1,000	500 °F (260 °C)	High speed/strength capability	Moderate cost	Gear boxes
	Outer Land	B2							
	Inner Land	S1		Steel – silver plate (machined)	1,500	900 °F (482 °C)	Higher speed/strength capability, corrosion resistant, lubricity	Higher cost – typically used with M50 rings and balls	Aircraft engine gear boxes
	Outer Land	S2							
	Outer Land	M3							
Crown, staggered cylindrical-spherical pocket	Ball	M8		PEEK● (molded)	1,000	500 °F (260 °C)	Light weight, high temperature/strength capability, abrasion resistant	Higher cost, limited availability – consult factory	High reliability, aerospace – power transmission
Crown, spherical pocket	Ball	M7		PA■ – glass reinforced (molded)	300	300 °F (149 °C)	Flexible – tolerates misalignment, low noise, abrasion/impact resistant	Low cost/high volume, hygroscopic (3%), limited availability – consult factory	Industrial, electric motors, munitions
Crown, cylindrical pocket	Inner Land	KE		Phenolic – linen base (machined)	600	300 °F (149 °C)	Lower mass-less centrifugal deflection, porous – can be impregnated with oil	Limited compatibility, hygroscopic, outgasses in a vacuum	Medical, machine tools, rotary joints, etc.
	Outer Land	KF							
	Inner Land	M6		PA■ – glass reinforced (molded)	300	300 °F (149 °C)	Flexible – tolerates misalignment, low noise, abrasion/impact resistant	Low cost/high volume, hygroscopic (3%), limited availability – consult factory	Industrial, electric motors, munitions

Please note: Additional cage designs and materials are available. Consult the factory for assistance.

† See page 7 for alphanumeric part number code.

◆ dN = bore (in millimeters) x rpm.

● PEEK = Polyetheretherketone is a high-melt-temperature thermoplastic.

■ PA = Polyamide (a.k.a. Nylon or Nylon 6/6) is a high-melt-temperature thermoplastic.

Lubrication

Selecting the best lubricant for a particular application is critical to achieving the full rated life of the bearing and optimal performance of the assembly, but choosing from the hundreds available can be an overwhelming task. The charts published on page 57 list a narrow selection of lubricants we use on a regular basis. They cover a wide range of temperatures, rotational speeds, load conditions and assembly designs. Please consult NHBB's Applications Engineering department before making your final selection.

Oil Lubricants

Petroleum and synthetic oil lubricants are used in conjunction with a circulating system that maintains the proper oil level and removes heat from the bearing assembly. While oil is suitable for a wide range of operating speeds, it is the preferred method of lubrication for high speed applications. Petroleum oils are still widely used because of their excellent performance characteristics at normal operating temperatures and medium to high speeds. Synthetic oils are used in many critical high speed and high temperature applications because they possess improved thermal properties, lower volatility and superior viscosity. Synthetic oils encompass a wide spectrum of engineered fluids including diesters, silicones and fluorinated compounds.

Grease

Grease is ideal for applications where frequent replenishment of a lubricant is undesirable or impossible. Compared to oil, grease has a limited speed capability because it does not remove heat from the bearing and increases torque. Grease consists of a base oil, thickeners and other additives. The base oil acts as the lubricating agent while thickeners keep the oil in suspension before releasing it under pressure. The additives function as anti-oxidants, rust inhibitors and stabilizers.

Solid Film

Solid film lubricants are used primarily in situations where oil and grease lubricants would fail, namely in harsh conditions characterized by extremely high or low temperatures, the chance for radiation exposure or the presence of a vacuum (e.g., space). Most solid film lubricants possess a finite operating life because they cannot be replenished once they wear away from the contact surfaces, which make them best suited for light load and low speed applications. Solid film lubricants encompass everything from sacrificial retainers to graphite powders, molybdenum-disulfide powders and ion sputtering. Detailed information on solid film lubricants has not been provided in this design guide, as each type must be engineered for the specific application.

Platings and Coatings

Plating and coating materials are typically used to help reduce surface wear and/or alleviate corrosion. The most widely specified plating material is Nodular Thin Dense Chrome (NTDC), more commonly referred to as "Thin Dense Chrome" or simply "TDC".

NTDC is a densified, nodular, chromium-rich material. It bonds to most substrates and is extremely hard (greater than 70 HRC). The unique micro-nodular surface features help to reduce the effective contact surface area, thereby lowering friction coefficients. The spaces between the nodular formations (microscopic scale) facilitate improved lubricant retention.

Because of the unique application process, precise geometric tolerances can be maintained.

Consideration should be given to the processing temperatures. The NTDC material must be post baked to remove any unwanted hydrogen. Plus, the post bake temperature must be below the tempering temperature of the ring material to ensure that dimensional stability and surface hardness are maintained.

Please contact NHBB's Applications Engineering department for details relating to other plating and coating options.

Lubrication

Oil Lubricants

NHBB CODE	BRAND NAME	TYPE	MILITARY SPECIFICATION	OPERATING TEMP.	GENERAL COMMENTS
LO1	Winsor Lube L-245X	Diester	MIL-PRF-6085	-65 – 300 °F	General purpose instrument oil, low volatility
LO2	Royco® 885	Diester	MIL-PRF-6085	-65 – 250 °F	General purpose instrument oil, low volatility
LO71	BP Turbo Oil 2389	Diester	MIL-PRF-7808	-65 – 300 °F	General purpose aircraft lubricant
LY115	Krytox® 143AC	Perfluorinated polyether		-30 – 550 °F	High temperature stability. Vacuum applications
LY223	Braycote® Micronic® 815Z	Perfluorinated polyether		-112 – 400 °F	Wide temperature range. Vacuum applications
LY378	Castrol® 399	Diester	MIL-PRF-7808	-65 – 300 °F	General purpose aircraft lubricant
LY559	Nye® Synthetic Oil 2001	Cyclopentane		-45 – 250 °F	Special oil for outer space & high vacuum applications

Grease Lubricants

NHBB CODE	BRAND NAME	TYPE OIL / THICKENER	MILITARY SPECIFICATION	OPERATING TEMP.	GENERAL COMMENTS
LG4	Aeroshell® 22	PAO/Microgel	MIL-PRF-81322	-85 – 400 °F	Wide temperature range, good low temp. torque. Aircraft, general purpose. NLGI 2*
LG20	Beacon 325	Diester/Lithium complex		-65 – 250 °F	General purpose instrument grease. NLGI 2*
LG49	Aeroshell® 7	Diester/Microgel		-100 – 300 °F	General purpose, low temp. torque, wide temperature range. NLGI 2*
LG68	Royco® 27	Diester/Lithium complex	MIL-PRF-23827	-100 – 275 °F	General purpose, low temp. torque, wide temperature range. NLGI 2*
LY17	Rheotemp® 500	Ester/Sodium complex		-65 – 350 °F	High speed, high temp. specialty lube. Spindle, instrument, and aircraft bearings. NLGI 2*
LY48	Mobilgrease® 28	PAO/Organo-clay	MIL-PRF-81322	-65 – 350 °F	Wide temperature range, good low temp. torque. Aircraft, general purpose. NLGI 2*
LY51	Isoflex® NBU15	Ester/Barium complex		-40 – 265 °F	High speed, spindle quality grease. NLGI 2*
LY101	Krytox® 240AC	Perfluorinated/PTFE	MIL-PRF-27617 Type III	-30 – 550 °F	High temperature stability, wide temperature range. Vacuum applications. NLGI 2*
LY308	Braycote® 601 EF	Perfluorinated/PTFE		-112 – 400 °F	Wide temperature range. Vacuum applications. NLGI 2*
LY548	Rheolube® 2000	Cyclopentane/Sodium complex		-45 – 250 °F	Special grease for outer space & high vacuum applications
LY660	Polyrex® EM	Mineral/Polyurea		-20 – 350 °F	Electric motor grease. Good high temperature grease. NLGI 2*
LY669	Rheolube® 374-C	PAO/Lithium complex		-40 – 300 °F	Channeling type grease, high speed. Good for vertical applications. NLGI 4*
LY703	Rheolube® 374-A	PAO/Lithium complex		-40 – 300 °F	General purpose grease. Good speed/temperature range. NLGI 2*
LY706	Kluberquiet® BQH 72-102	Ester/Polyurea		-45 – 350 °F	Quiet running, wide temperature range. NLGI 2*

*National Lubricating Grease Institute number refers to grease thickness.

Registered Trademarks

Aeroshell® – Royal Dutch Shell Plc.

Brayco® Micronic®, Castrol® – Castrol Limited.

Isoflex®, Kluberquiet® – Klüber Lubrication, a company of the Freudenberg Group.

Krytox® – DuPont de Nemours, Inc.

Mobilgrease®, Polyrex® – Exxon Mobil Corporation.

Royco® – Anderol Company.

Nye®, Rheotemp®, Rheolube® – Nye Lubricants, Inc.

Tolerances

NHBB manufactures bearings to a variety of ABEC tolerance levels. Our smaller thin section and torque tube series of bearings are manufactured to ABEC 5T and 7T tolerances as described in ABMA Std. 12.2. Larger diameter thin cross section bearings are manufactured to ABEC 1F, 3F, 5F or 7F tolerances as noted in ABMA Std. 26.2, and our metric series bearings are manufactured to ABEC/RBEC 1, 3, 5 or 7 tolerances as outlined in ABMA Std. 20.

The choice of precision level is dependent on the requirements of the application. The lower classes (ABEC 1 and 3) are suitable for applications with lower speed and accuracy needs. These bearings provide a more favorable cost-to-performance ratio. Applications with the need for higher speed, lower torque or greater positional accuracy will most likely require higher precision grades. Please contact NHBB's Applications Engineering department for assistance in selecting the proper tolerance class.

Inner Ring

TOLERANCES IN INCHES														
Bore Size (mm)		Bore Diameter Tolerance ABEC/RBEC Class					Radial Runout Maximum ABEC/RBEC Class					Ring Width		
												ABEC 1 & 3	ABEC 5, 7 & 9	Duplex
OVER	INCL.	1	3	5	7	9	1	3	5	7	9	SINGLE	SINGLE	INDIVIDUAL RING
—	10	.00030	.00030	.00020	.00015	.00010	.00040	.00025	.00015	.00010	.00005	.0047	.0016	.0098
10	18	.00030	.00030	.00020	.00015	.00010	.00040	.00030	.00015	.00010	.00005	.0047	.0031	.0098
18	30	.00040	.00030	.00025	.00020	.00010	.00050	.00030	.00015	.00010	.00010	.0047	.0047	.0098
30	50	.00045	.00040	.00030	.00025	.00010	.00060	.00040	.00020	.00015	.00010	.0047	.0047	.0098
50	80	.00060	.00045	.00035	.00030	.00015	.00080	.00040	.00020	.00015	.00010	.0059	.0059	.0098
80	120	.00080	.00060	.00040	.00030	.00020	.00100	.00050	.00025	.00020	.00010	.0079	.0079	.0150
120	180	.00100	.00070	.00050	.00040	.00030	.00120	.00070	.00030	.00025	.00015	.0098	.0098	.0150
180	250	.00120	.00085	.00060	.00045	.00030	.00160	.00080	.00040	.00030	.00020	.0118	.0118	.0197

Outer Ring

TOLERANCES IN INCHES														
Bore Size (mm)		Bore Diameter Tolerance ABEC/RBEC Class					Radial Runout Maximum ABEC/RBEC Class					Ring Width		
												ABEC 1 & 3	ABEC 5, 7 & 9	Duplex
OVER	INCL.	1	3	5	7	9	1	3	5	7	9	SINGLE	SINGLE	INDIVIDUAL RING
18	30	.00035	.00030	.00025	.00020	.00015	.00060	.00035	.00025	.00015	.00010	.0047	.0016	.0098
30	50	.00045	.00035	.00030	.00025	.00015	.00080	.00040	.00030	.00020	.00010	.0047	.0031	.0098
50	80	.00050	.00045	.00035	.00030	.00015	.00100	.00050	.00030	.00020	.00015	.0047	.0047	.0098
80	120	.00060	.00050	.00040	.00030	.00020	.00140	.00070	.00040	.00025	.00020	.0047	.0047	.0098
120	150	.00070	.00060	.00045	.00035	.00020	.00160	.00080	.00045	.00030	.00020	.0059	.0059	.0098
150	180	.00100	.00070	.00050	.00040	.00030	.00180	.00090	.00050	.00030	.00020	.0079	.0079	.0150
180	250	.00120	.00080	.00060	.00045	.00030	.00200	.00100	.00060	.00040	.00030	.0098	.0098	.0150
250	315	.00140	.00100	.00070	.00050	.00030	.00240	.00120	.00070	.00045	.00030	.0118	.0118	.0197

Please note: Industry standards for tolerances are issued and maintained by the American Bearing Manufacturers Association (ABMA), of which NHBB is an active member. Standards are established with input from ABMA associated bearing technical committees, Annular Bearing Engineers' Committee (ABEC), Roller Bearing Engineers' Committee (RBEC), and engineers and managers from member bearing manufacturers.

Ball Grades

Balls are manufactured to the precision requirements noted in ANSI/ABMA Std. 10A for steel balls and ASTM F2094 for ceramic balls. These standards require that balls meet the limits for ball diameter, spherical form and roughness noted below for each grade level. Lower grade numbers denote more precise

balls, which help to improve accuracy, reduce running torque, lengthen lube life and reduce noise. With few exceptions, NHBB manufactures its precision bearings with grade 10A and 10C balls or better.

Individual Balls

BALL GRADE		VARIATION OF BALL DIAMETER (0.000001 IN.)	DEVIATION FROM SPHERICAL FORM (0.000001 IN.)	SURFACE ROUGHNESS RA MAX.	
STEEL	CERAMIC			STEEL	CERAMIC
G3A	3C	3	3	0.40	0.15
G5A	5C	5	5	0.56	0.20
G10A	10C	10	10	0.80	0.25
G16A	16C	16	16	1.00	0.35
G24A	24C	24	24	2.60	0.50

Lots

BALL GRADE		DEVIATION FROM BALL LOT DIAMETER (0.000001 IN.)
STEEL	CERAMIC	
G3A	3C	5
G5A	5C	10
G10A	10C	20
G16A	16C	32
G24A	24C	48

Silicon Nitride Balls

Engineered specifically for bearings, silicon nitride (ceramic) balls possess highly controlled, consistent geometry and extremely smooth and consistent surface finish. The stiffness, light weight and inertness of silicon nitride balls offer significant bearing performance advantages, including higher operating speeds, lower heat generation, extended bearing life and

expanded design possibilities for unique and demanding bearing applications. In addition, the dissimilar materials between the ceramic balls and the steel rings minimize cold welding and adhesive wear. Ceramic balls are particularly well suited for high speed applications and in situations where marginal lubrication is a possibility.

Typical Applications

- Micro turbines (power generation)
- Aircraft instrumentation
- Gas turbine engines
- Hot air valves
- Helicopter gear boxes
- Accessory gear boxes



Specifications

MATERIAL	SPECIFICATIONS	ATTRIBUTES	ROOM TEMP. HARDNESS
Silicon nitride	ASTM F2094	Extended life, lower torque, lighter weight, higher stiffness	>1380 HV10 (>78 HRC)

Performance Benefits

PROPERTIES	IMPROVEMENT IN BEARING PERFORMANCE
Lower internal friction	Lower internal temperature Reduced cage and raceway wear
Lighter weight <i>58% lighter than steel</i>	Lighter overall bearing weight Decreased centrifugal force Decreased gyroscopic movement
Higher stiffness & higher hardness	Reduced skidding Less friction Lower operating temperatures Less wear
Smoother surface <i>65% smoother than steel</i>	Decreased lube degradation No cold welding/adhesive wear Less friction Lower operating temperature Less wear
Corrosion resistance	Durability in harsh environments Less wear Resists galling
Higher maximum temperature	Wider operating range

Engineering Analysis and Reporting

HiTech's ball and roller bearings have a solid reputation for quality, reliability and consistency. However, bearings—like any mechanical device—are subject to serviceability issues. Failure may occur due to improper mounting, lubrication, environment, loading, maintenance, or contamination after installation.

NHBB has a versatile technical staff with extensive experience in the analysis of ball and roller bearings in the event of failure. Using specialized knowledge, analytical tools and precision measuring and testing equipment, the cause for bearing failure can often be determined quickly and succinctly.

Requirements

Specific hardware and/or information is required to successfully perform a bearing analysis:

- All bearing hardware, preferably in the assembled state as removed from the application with minimal disruption;
- Installation information, including interfacing hardware details, materials and fit-up;
- Bearing serial numbers and manufacturing lot numbers, if available;
- Historical information describing the conditions under which the bearings operated, including speeds, loads, temperatures and atmospheric conditions, as well as any unusual shock, vibration, electrical arcing or handling situations to which the bearing was subjected.

When service or failure analysis is required, please contact NHBB's Applications Engineering department.



ADIFOR AERO



Temperature Conversion Table

The numbers in the center column refer to the temperatures either in Celsius or Fahrenheit which need conversion to the other scale. When converting from Fahrenheit to Celsius, the

equivalent temperature will be found to the left of the center column. If converting from Celsius to Fahrenheit, the answer will be found to the right.

Celsius to Fahrenheit Conversion Table

°C	°F/°C	°F	°C	°F/°C	°F	°C	°F/°C	°F	°C	°F/°C	°F
-79	-110	-166	37.8	100	212	204	400	752	371	700	1292
-73	-100	-148	43	110	230	210	410	770	377	710	1310
-68	-90	-130	49	120	248	216	420	788	382	720	1328
-62	-80	-112	54	130	266	221	430	806	388	730	1346
-57	-70	-94	60	140	284	227	440	824	393	740	1364
-51	-60	-76	66	150	302	232	450	842	399	750	1382
-46	-50	-58	71	160	320	238	460	860	404	760	1400
-40	-40	-40	77	170	338	243	470	878	410	770	1418
-34	-30	-22	82	180	356	249	480	896	416	780	1436
-29	-20	-4	88	190	374	254	490	914	421	790	1454
-23	-10	14	93	200	392	260	500	932	427	800	1472
-17.8	0	32	99	210	410	266	510	950	432	810	1490
-17.2	1	33.8	104	220	428	271	520	968	438	820	1508
-16.7	2	35.6	110	230	446	277	530	986	443	830	1526
-16.1	3	37.4	116	240	464	282	540	1004	449	840	1544
-15.6	4	39.2	121	250	482	288	550	1022	454	850	1562
-15.0	5	41.0	127	260	500	293	560	1040	460	860	1580
-14.4	6	42.8	132	270	518	299	570	1058	466	870	1598
-13.9	7	44.6	138	280	536	304	580	1076	471	880	1616
-13.3	8	46.4	143	290	554	310	590	1094	477	890	1634
-12.8	9	48.2	149	300	572	316	600	1112	482	900	1652
-12.2	10	50.5	154	310	590	321	610	1130	488	910	1670
-6.7	20	68	160	320	608	327	620	1148	493	920	1688
-1.1	30	86	166	330	626	332	630	1166	499	930	1706
4.4	40	104	171	340	644	338	640	1184	504	940	1724
10	50	122	177	350	662	343	650	1202	510	950	1742
15.6	60	140	182	360	680	349	660	1220	516	960	1760
21.1	70	158	188	370	698	354	670	1238	521	970	1778
26.7	80	176	193	380	716	360	680	1256	527	980	1796
32.2	90	194	199	390	734	366	690	1274	532	990	1814

Inch/Metric Conversion Table

Example: To look up the inch equivalent of 15 mm, find 10 on the horizontal axis and 5 on the vertical axis. Their intersection is the inch equivalent. 15 mm = .59055 inch. 1 inch = 25.4 mm.

Millimeters to Inches

mm	0	10	20	30	40	50
0	0.00000	0.39370	0.78740	1.18110	1.57480	1.96850
1	0.03937	0.43307	0.82677	1.22047	1.61417	2.00787
2	0.07874	0.47244	0.86614	1.25984	1.65354	2.04724
3	0.11811	0.51181	0.90551	1.29921	1.69291	2.08661
4	0.15748	0.55118	0.94488	1.33858	1.73228	2.12598
5	0.19685	0.59055	0.98425	1.37795	1.77165	2.16535
6	0.23622	0.62992	1.02362	1.41732	1.81102	2.20472
7	0.27559	0.66929	1.06299	1.45669	1.85039	2.24409
8	0.31496	0.70866	1.10236	1.49606	1.88976	2.28346
9	0.35433	0.74803	1.14173	1.53543	1.92913	2.32283
mm	60	70	80	90	100	110
0	2.36220	2.75591	3.14961	3.54331	3.93701	4.33071
1	2.40157	2.79528	3.18898	3.58268	3.97638	4.37008
2	2.44094	2.83465	3.22835	3.62205	4.01575	4.40945
3	2.48031	2.87402	3.26772	3.66142	4.05512	4.44882
4	2.51969	2.91339	3.30709	3.70079	4.09449	4.48819
5	2.55906	2.95276	3.34646	3.74016	4.13386	4.52756
6	2.59843	2.99213	3.38583	3.77953	4.17323	4.56693
7	2.63780	3.03150	3.42520	3.81890	4.21260	4.60630
8	2.67717	3.07087	3.46457	3.85827	4.25197	4.64567
9	2.71654	3.11024	3.50394	3.89764	4.29134	4.68504
mm	120	130	140	150	160	170
0	4.72441	5.11811	5.51181	5.90551	6.29921	6.69291
1	4.76378	5.15748	5.55118	5.94488	6.33858	6.73228
2	4.80315	5.19685	5.59055	5.98425	6.37795	6.77165
3	4.84252	5.23622	5.62992	6.02362	6.41732	6.81102
4	4.88189	5.27559	5.66929	6.06299	6.45669	6.85039
5	4.92126	5.31496	5.70866	6.10236	6.49606	6.88976
6	4.96063	5.35433	5.74803	6.14173	6.53543	6.92913
7	5.00000	5.39370	5.78740	6.18110	6.57480	6.96850
8	5.03937	5.43307	5.82677	6.22047	6.61417	7.00787
9	5.07874	5.47244	5.86614	6.25984	6.65354	7.04724
mm	180	190	200	210	220	230
0	7.08661	7.48031	7.87402	8.26772	8.66142	9.05512
1	7.12598	7.51969	7.91339	8.30709	8.70079	9.09449
2	7.16535	7.55906	7.95276	8.34646	8.74016	9.13386
3	7.20472	7.59843	7.99213	8.38583	8.77953	9.17323
4	7.24409	7.63780	8.03150	8.42520	8.81890	9.21260
5	7.28346	7.67717	8.07087	8.46457	8.85827	9.25197
6	7.32283	7.71654	8.11024	8.50394	8.89764	9.29134
7	7.36220	7.75591	8.14961	8.54331	8.93701	9.33071
8	7.40157	7.79528	8.18898	8.58268	8.97638	9.37008
9	7.44094	7.83465	8.22835	8.62205	9.01575	9.40945

Fractional to Decimal Conversions

Fraction Inch	Decimal Inch	Decimal mm
1/64	0.01563	0.3969
1/32	0.03125	0.7938
3/64	0.04688	1.1906
1/16	0.06250	1.5875
5/64	0.07813	1.9844
3/32	0.09375	2.3813
7/64	0.10938	2.7781
1/8	0.12500	3.1750
9/64	0.14063	3.5719
5/32	0.15625	3.9688
11/64	0.17188	4.3656
3/16	0.18750	4.7625
13/64	0.20313	5.1594
7/32	0.21875	5.5563
15/64	0.23438	5.9531
1/4	0.25000	6.3500
17/64	0.26563	6.7469
9/32	0.28125	7.1438
5/16	0.31250	7.9375
11/32	0.34375	8.7313
3/8	0.37500	9.5250
13/32	0.40625	10.3188
7/16	0.43750	11.1125
15/32	0.46875	11.9063
1/2	0.50000	12.7000
7/64	0.10938	2.7781
17/32	0.53125	13.4938
9/16	0.56250	14.2875
19/32	0.59375	15.0813
5/8	0.62500	15.8750
11/16	0.68750	17.4625
3/4	0.75000	19.0500
13/16	0.81250	20.6375
7/8	0.87500	22.2250
15/16	0.93750	23.8125
1	1.00000	25.4000
1-1/16	1.06250	26.9875
1-1/8	1.12500	28.5750
1-3/16	1.18750	30.1625
1-1/4	1.25000	31.7500
1-5/16	1.31250	33.3375

COMMITTED TO EXCELLENCE

We continue to build strong alliances within the aerospace, medical/dental and high tech industries, working across the enterprise to provide business solutions that keep pace with our customers' technological advances.

The precision tolerances required by the customers we support necessitate a complete commitment to quality. At NHBB, that commitment is apparent in everything we do, from an investment in advanced capabilities, to real-time quality control, to continuous improvement in both processes and people. Our commitment to manufacturing excellence is seen time and again in our high level of service and product quality.

APPLICATIONS ENGINEERING

Knowing how to leverage knowledge, industry experience, emerging technology and industry trends is the true differentiator when it comes to customized bearing assemblies. At NHBB, we offer complete bearing engineering support for every phase of a product's life cycle, and we do this with a passion for serving as a vital technical resource to our customers.

MANUFACTURING

Investing in the most advanced technologies available gives NHBB a significant advantage in precision manufacturing. We're able to guarantee the close tolerances necessary in life-critical and high speed applications, as well as address manufacturing challenges in-house through new tools, precision gages and state-of-the-art production processes.

CARE FOR THE ENVIRONMENT

At NHBB, our stringent environmental policy emphasizes pollution prevention, regulatory compliance, and continuous improvement aimed at reducing the impact of every phase of the manufacturing process. Our objectives also include the promotion of environmental awareness among employees and within our communities.

ADIFOR AERO

PRODUCTS:

- Rod ends
- Sphericals
- Link assemblies
- Bushings
- Loader slot bearings
- Custom-lined parts
- Bearings up to 22" O.D.
- Next-up assemblies & machined parts



NMB, KARUIZAWA, JAPAN:*

- Rod ends
- Sphericals
- Spherical roller bearings
- Self-aligning roller bearings
- Next-up assemblies & machined parts



CERTIFICATIONS/APPROVALS:

- ISO 9001:2000
- AS9100, Rev B
- Boeing D6-82479
- ISO 14001:2004 – environmental management

NADCAP:

- AC7102 – Heat-treating
- AC7108 – Chemical processing
- AC7114 – Nondestructive testing
- AC7118 – Composites – self-lubricating liner adhesive bonding process



*Astro is the North and South American sales representative for products manufactured by NMB's facility in Karuizawa, Japan, giving customers access to a global supply of high quality commercial aerospace parts.

Precision Division, Chatsworth, CA

Keeping Technology on the Move®

PRODUCTS:

- Ultra-precision miniature & instrument ball bearings
 - Inch and metric
 - Hybrid ceramics
 - Torque tube/thin section
 - Duplex/super duplex
- Airframe control bearings
- Modified dimensions
 - Special bore, O.D. and width
 - Custom designs
- Machined cages
 - Phenolic, Torlon®, Delrin®, Meldin®
- Mechanical assemblies
- Middle size bearings (up to 3" O.D.)



CERTIFICATIONS/APPROVALS:

- ISO 9001:2000
- AS9100, Rev B
- ISO 14001:2004 – environmental management

NADCAP:

- AC7102 – Heat-treating



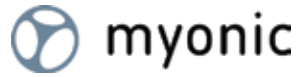

PRODUCTS:

- Ultra precision miniature ball bearings
 - Deep groove radial
 - Angular contact
 - Full line of metric
- Thrust bearings
- X-ray tube bearings
- Aircraft instrument bearings
- Dental bearings
 - Integral shaft
 - Complete turbine assemblies
 - Laser welded shields
 - Hybrid ceramic
 - Spindles/auto chucks
- Shims and washers
- Customized bearing systems
- Contract manufactured products

CERTIFICATION:

- ISO 9001:2008



ADIFOR AERO



New Hampshire Ball Bearings is an integral part of an international business. Its parent company, Minebea Co., Ltd., is the world's leading specialized manufacturer of miniature ball bearings and high precision components for the telecommunications, aerospace, automotive and electrical appliance industries.

The Minebea Group is comprised of 40 subsidiaries in 16 countries, and employs 44,000 people. In addition to its worldwide manufacturing capabilities, Minebea's vision is to lead the competition through extensive research and development of new methods and technologies.



ADIFOR AERO



ADIFOR AERO



New Hampshire Ball Bearings, Inc.

— *A Minebea Company* —

HiTech Division

175 Jaffrey Road

Peterborough, NH 03458

tel: 603.924.4100 fax: 603.924.9302

**Precision Division and
Corporate Headquarters**

9700 Independence Avenue

Chatsworth, CA 91311

tel: 818.993.4100 fax: 818.407.5020

Astro Division

155 Lexington Drive

Laconia, NH 03246

tel: 603.524.0004 fax: 603.524.9025

myonic USA

9700 Independence Avenue

Chatsworth, CA 91311

tel: 818.701.4833 fax: 818.407.5020

NHBB Europe

Siemensstrasse 30

63225 Langen

Germany

tel: (49) 6103.913.341 fax: (49) 6103.913.342

www.nhbb.com

